

CSD25310Q2 20V P 沟道 NexFET™ 功率 MOSFET

1 特性

- 超低 Q_g 和 Q_{gd}
- 低导通电阻
- 低热阻
- 无铅
- 符合 RoHS
- 无卤素
- SON 2mm × 2mm 塑料封装

2 应用

- 电池管理
- 负载管理
- 电池保护

3 说明

这款 19.9mΩ、-20V P 沟道器件旨在以超薄且具有出色散热特性的极小封装提供更低的导通电阻和栅极电荷。该器件将低导通电阻与 SON 2mm × 2mm 塑料封装的极小封装尺寸融为一体，堪称电池供电型空间受限应用的理想之选。

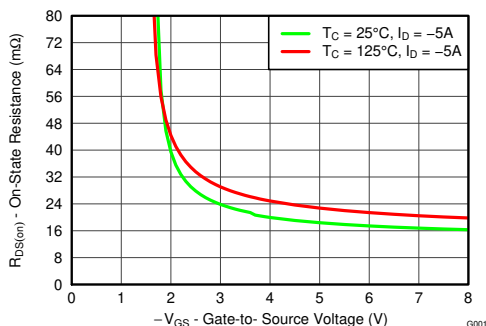

$R_{DS(on)}$ 与 V_{GS} 之间的关系

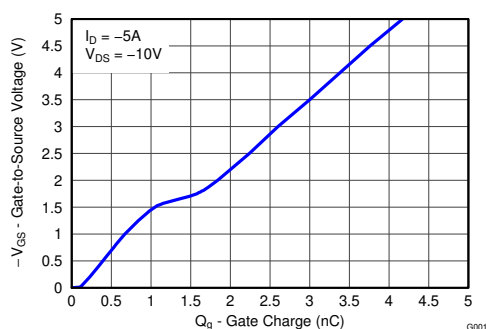

栅极电荷

产品概要

$T_A = 25^\circ\text{C}$		典型值		单位
V_{DS}	漏源电压	-20		V
Q_g	栅极电荷总量 (-4.5V)	3.6		nC
Q_{gd}	栅漏栅极电荷	0.5		nC
$R_{DS(on)}$	漏源导通电阻	$V_{GS} = -1.8\text{V}$	59.0	mΩ
		$V_{GS} = -2.5\text{V}$	27.0	mΩ
		$V_{GS} = -4.5\text{V}$	19.9	mΩ
$V_{GS(th)}$	阈值电压	-0.85		V

订购信息

器件	介质	数量	封装	配送
CSD25310Q2	7 英寸卷带	3000	SON 2 x 2mm	卷带包装
CSD25310Q2T	7 英寸卷带	250	塑料封装	

绝对最大额定值

$T_A = 25^\circ\text{C}$		值	单位
V_{DS}	漏源电压	-20	V
V_{GS}	栅源电压	±8	V
I_D	持续漏极电流 (受封装限制)	-20	A
	持续漏极电流(1)	-9.6	A
I_{DM}	脉冲漏极电流(2)	48	A
P_D	功率耗散	2.9	W
	1. $R_{\theta JA} = 43^\circ\text{C/W}$, 这是在一块厚度为 0.06 英寸环氧树脂 (FR4) 印刷电路板 (PCB) 上的 1 平方英寸 (2 盎司) 覆铜上测得的典型值。		
T_J, T_{stg}	运行结温和储存温度范围	-55 至 150	°C



图 3-1. 顶视图



Table of Contents

1 特性	1	6 Device and Documentation Support	6
2 应用	1	6.1 Trademarks.....	6
3 说明	1	7 Mechanical, Packaging, and Orderable Information	7
4 Revision History	2	7.1 Q2 Package Dimensions.....	7
5 Specifications	3	7.2 Recommended PCB Pattern.....	8
5.1 Electrical Characteristics.....	3	7.3 Recommended Stencil Pattern.....	8
5.2 Thermal Information.....	4	7.4 Q2 Tape and Reel Information.....	9
5.3 Typical MOSFET Characteristics.....	5		

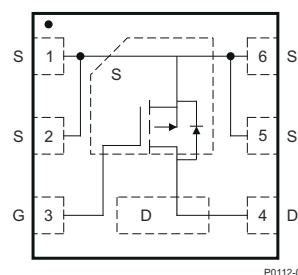
4 Revision History

Changes from Revision A (June 2014) to Revision B (March 2022)	Page
• Updated drain and source connection images.....	4

Changes from Revision * (January 2014) to Revision A (June 2014)	Page
• 已将“无铅端子镀层”修改为唯一状态“无铅”.....	1
• 在订购信息表中添加了小卷带选项.....	1

5 Specifications

5.1 Electrical Characteristics

T_A = 25°C, unless otherwise specified

PARAMETER		TEST CONDITIONS	MIN	TYP	MAX	UNIT
STATIC CHARACTERISTICS						
B _V DSS	Drain-to-Source Voltage	V _{GS} = 0 V, I _D = - 250 μA	- 20			V
I _{DSS}	Drain-to-Source Leakage Current	V _{GS} = 0 V, V _{DS} = - 16 V			- 1	μA
I _{GSS}	Gate-to-Source Leakage Current	V _{DS} = 0 V, V _{GS} = - 8 V			- 100	nA
V _{GS(th)}	Gate-to-Source Threshold Voltage	V _{DS} = V _{GS} , I _{DS} = - 250 μA	- 0.55	- 0.85	- 1.10	V
R _{DS(on)}	Drain-to-Source On Resistance	V _{GS} = - 1.8 V, I _{DS} = - 5 A		59.0	89.0	mΩ
		V _{GS} = - 2.5 V, I _{DS} = - 5 A		27.0	32.5	mΩ
		V _{GS} = - 4.5 V, I _{DS} = - 5 A		19.9	23.9	mΩ
g _{fs}	Transconductance	V _{DS} = - 16 V, I _{DS} = - 5 A		34		S
DYNAMIC CHARACTERISTICS						
C _{ISS}	Input Capacitance	V _{GS} = 0 V, V _{DS} = - 10 V, f = 1 MHz		504	655	pF
C _{OSS}	Output Capacitance			281	365	pF
C _{RSS}	Reverse Transfer Capacitance			16.7	21.7	pF
R _g	Series Gate Resistance			1.9		Ω
Q _g	Gate Charge Total (- 4.5 V)	V _{DS} = - 10 V, I _{DS} = - 5 A		3.6	4.7	nC
Q _{gd}	Gate Charge Gate to Drain			0.5		nC
Q _{gs}	Gate Charge Gate to Source			1.1		nC
Q _{g(th)}	Gate Charge at V _{th}			0.6		nC
Q _{OSS}	Output Charge		V _{DS} = - 10 V, V _{GS} = 0 V		5.0	
t _{d(on)}	Turn On Delay Time	V _{DS} = - 10 V, V _{GS} = - 4.5 V, I _{DS} = - 5 A R _G = 2 Ω		8		ns
t _r	Rise Time			15		ns
t _{d(off)}	Turn Off Delay Time			15		ns
t _f	Fall Time			5		ns
DIODE CHARACTERISTICS						
V _{SD}	Diode Forward Voltage	I _{DS} = - 5 A, V _{GS} = 0 V		- 0.8	- 1.0	V
Q _{rr}	Reverse Recovery Charge	V _{DD} = - 10 V, I _F = - 5 A, di/dt = 200 A/μs		9.2		nC
t _{rr}	Reverse Recovery Time			13		ns

5.2 Thermal Information

($T_A = 25^\circ\text{C}$ unless otherwise stated)

THERMAL METRIC		MIN	TYP	MAX	UNIT
$R_{\theta JC}$	Thermal Resistance Junction to Case ⁽¹⁾			4.5	°C/W
$R_{\theta JA}$	Thermal Resistance Junction to Ambient ^{(1) (2)}			55	

- (1) $R_{\theta JC}$ is determined with the device mounted on a 1-inch² (6.45-cm²), 2-oz. (0.071-mm thick) Cu pad on a 1.5-inch × 1.5-inch (3.81-cm × 3.81-cm), 0.06-inch (1.52-mm) thick FR4 PCB. $R_{\theta JC}$ is specified by design, whereas $R_{\theta JA}$ is determined by the user's board design.
- (2) Device mounted on FR4 material with 1-inch² (6.45-cm²), 2-oz. (0.071-mm thick) Cu.

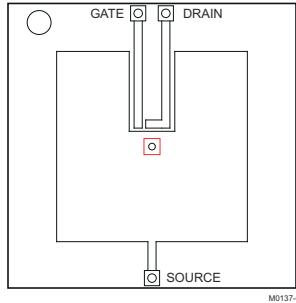

Max $R_{\theta JA} = 55$ when mounted on 1 inch² (6.45 cm²) of 2-oz. (0.071-mm thick) Cu.

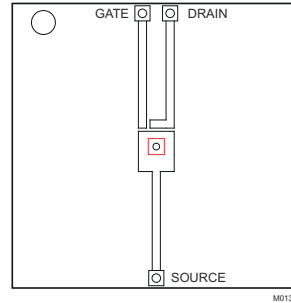

Max $R_{\theta JA} = 215$ when mounted on minimum pad area of 2-oz. (0.071-mm thick) Cu.

5.3 Typical MOSFET Characteristics

($T_A = 25^\circ\text{C}$ unless otherwise stated)

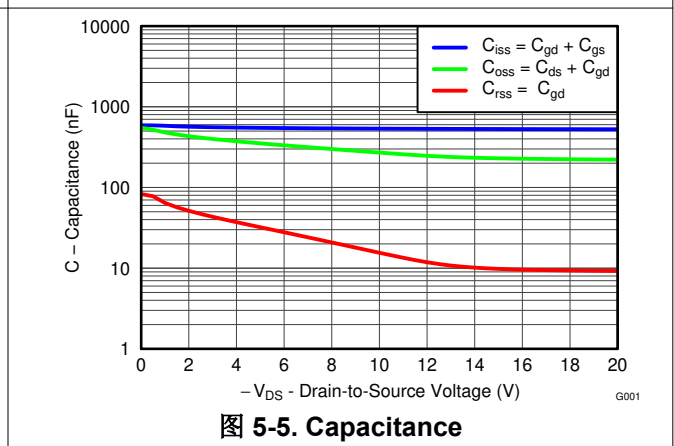
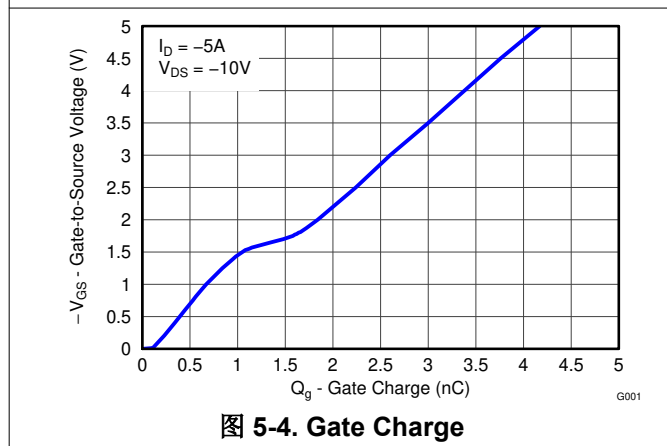
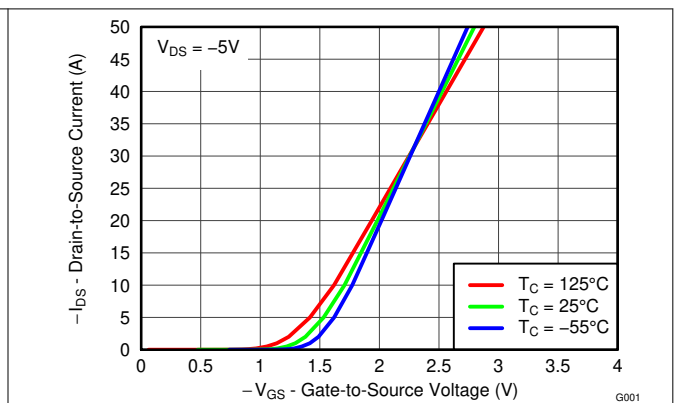
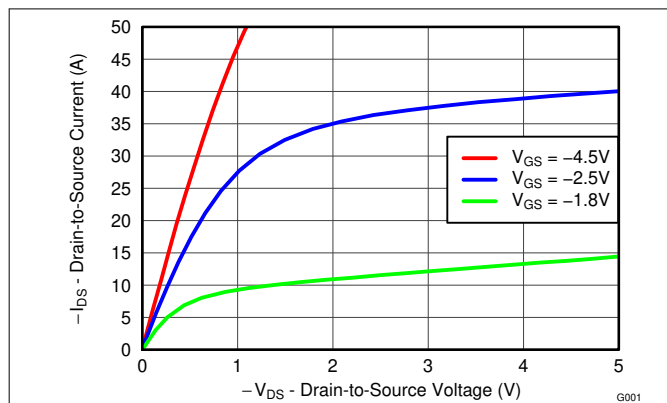
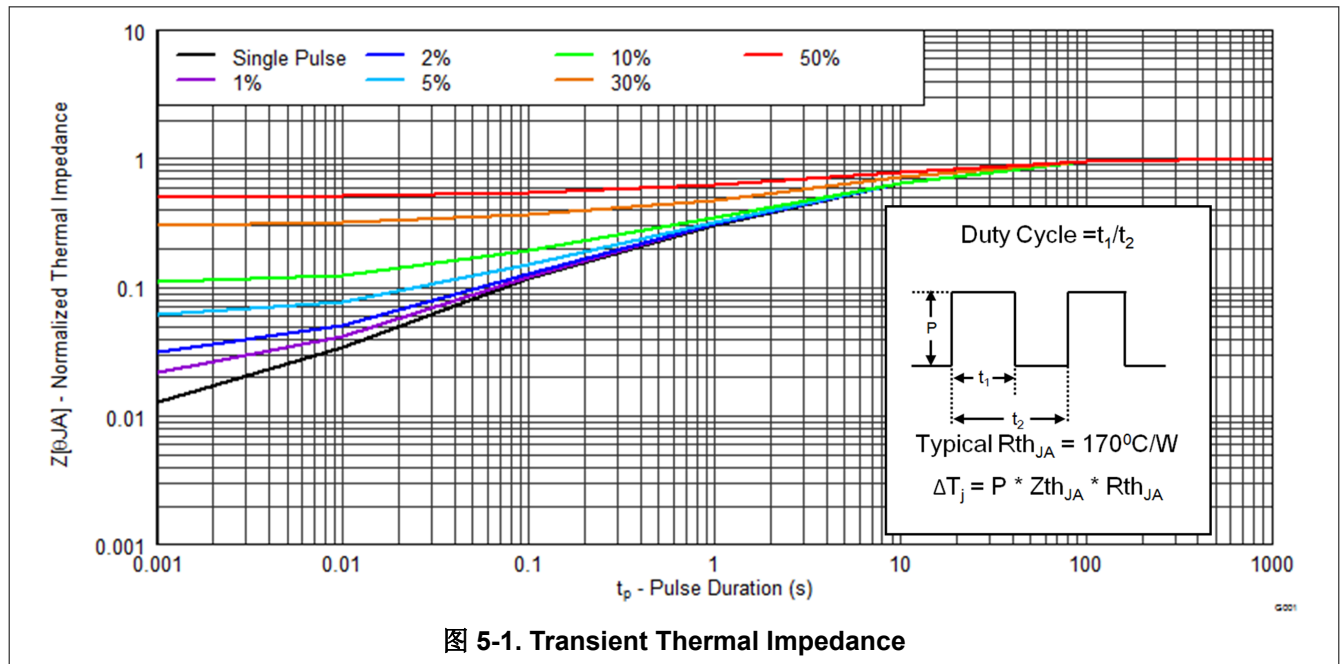



图 5-6. Threshold Voltage vs Temperature



图 5-7. On-State Resistance vs Gate-to-Source Voltage

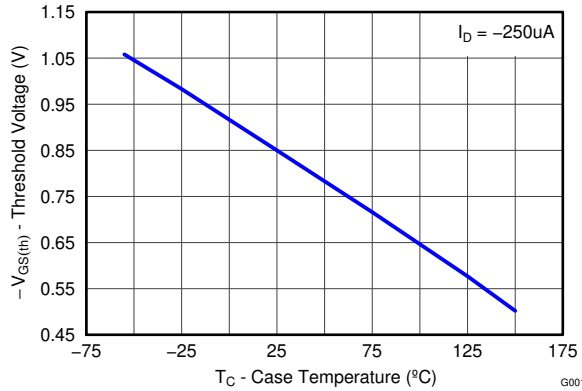

图 5-8. Normalized On-State Resistance vs Temperature

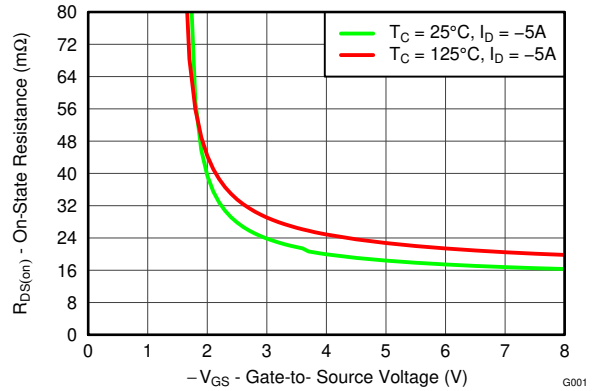

图 5-9. Typical Diode Forward Voltage

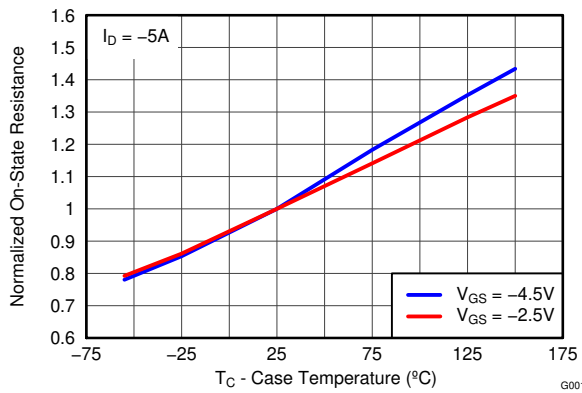

图 5-10. Maximum Safe Operating Area

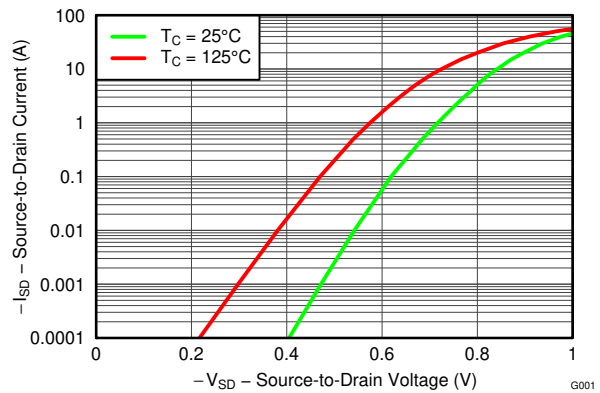

图 5-11. Maximum Drain Current vs Temperature

6 Device and Documentation Support

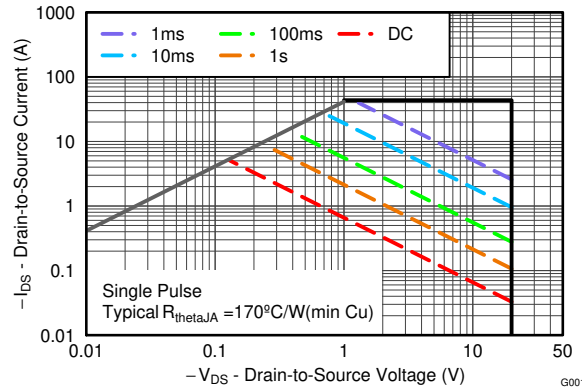
6.1 Trademarks

NexFET™ is a trademark of TI.

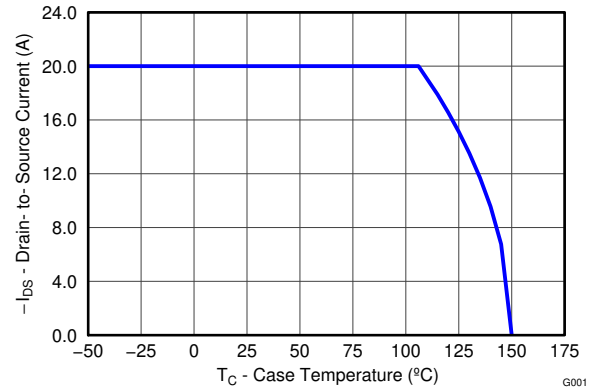
所有商标均为其各自所有者的财产。

7 Mechanical, Packaging, and Orderable Information

The following pages include mechanical packaging and orderable information. This information is the most current data available for the designated devices. This data is subject to change without notice and revision of this document. For browser-based versions of this data sheet, refer to the left-hand navigation.

7.1 Q2 Package Dimensions

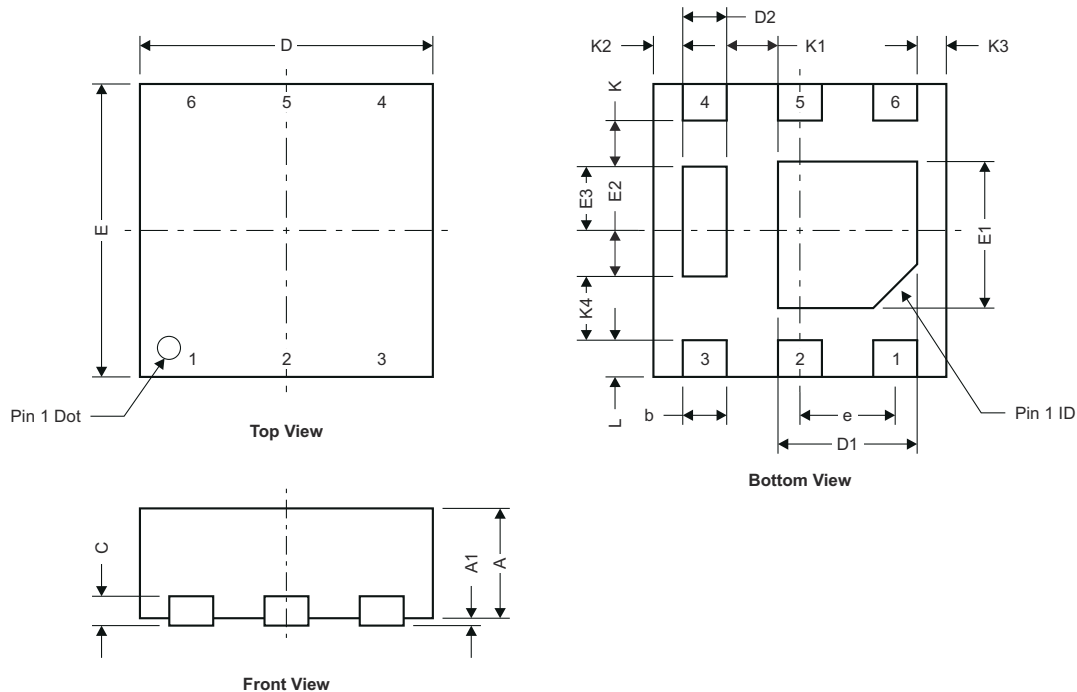

M0165-01

DIM	MILLIMETERS			INCHES		
	MIN	NOM	MAX	MIN	NOM	MAX
A	0.700	0.750	0.800	0.028	0.030	0.032
A1	0.000		0.050	0.000		0.002
b	0.250	0.300	0.350	0.010	0.012	0.014
C	0.203 TYP			0.008 TYP		
D	2.000 TYP			0.080 TYP		
D1	0.900	0.950	1.000	0.036	0.038	0.040
D2	0.300 TYP			0.012 TYP		
E	2.000 TYP			0.080 TYP		
E1	0.900	1.000	1.100	0.036	0.040	0.044
E2	0.280 TYP			0.0112 TYP		
E3	0.470 TYP			0.0188 TYP		
e	0.650 TYP			0.026 TYP		
K	0.280 TYP			0.0112 TYP		
K1	0.350 TYP			0.014 TYP		
K2	0.200 TYP			0.008 TYP		
K3	0.200 TYP			0.008 TYP		
K4	0.470 TYP			0.0188 TYP		
L	0.200	0.25	0.300	0.008	0.010	0.012

7.2 Recommended PCB Pattern

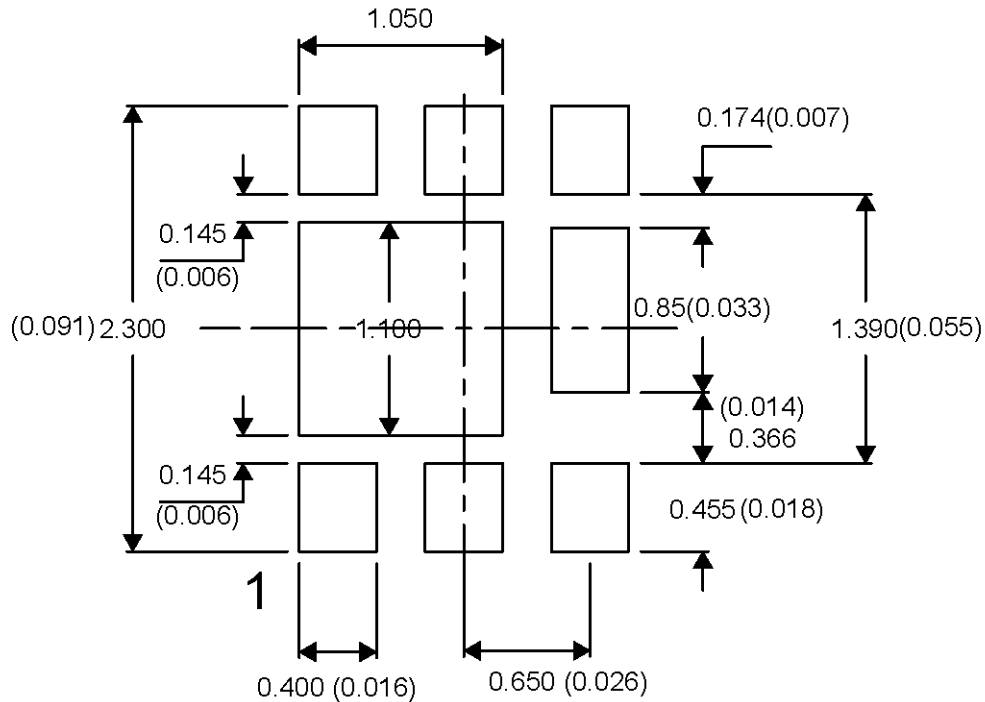

For recommended circuit layout for PCB designs, see application note [SLPA005](#) - *Reducing Ringing Through PCB Layout Techniques*.

7.3 Recommended Stencil Pattern

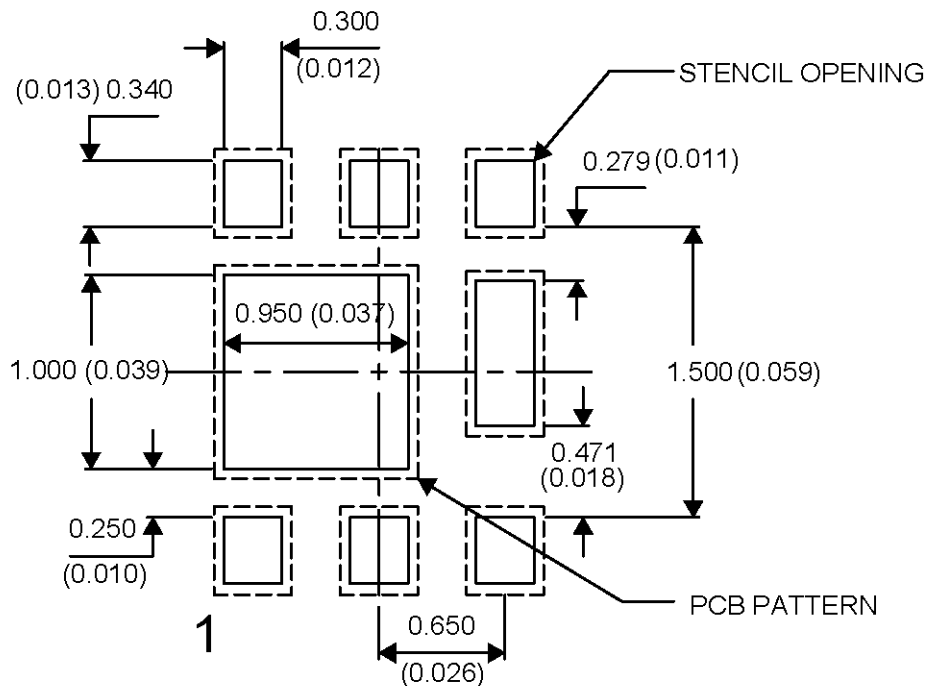

All dimensions are in mm, unless otherwise specified.

7.4 Q2 Tape and Reel Information

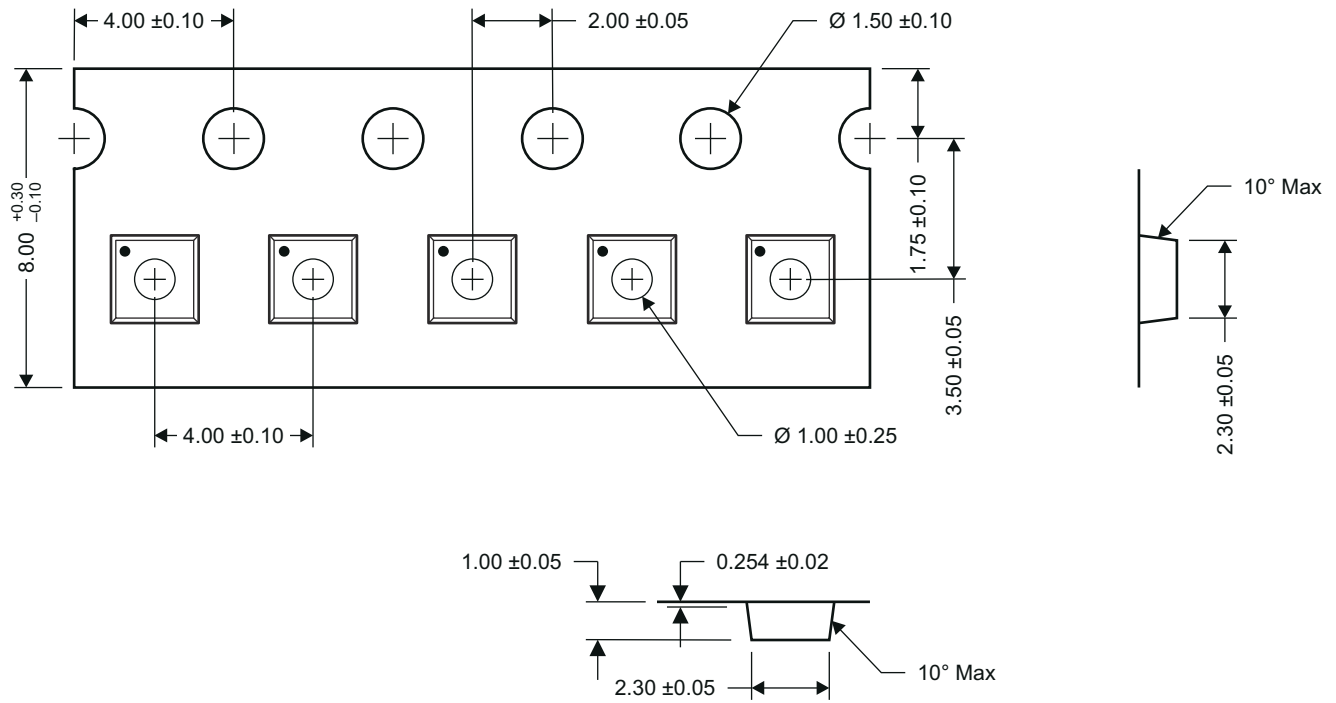

1. Measured from centerline of sprocket hole to centerline of pocket
2. Cumulative tolerance of 10 sprocket holes is ± 0.20
3. Other material available
4. Typical SR of form tape Max 10^9 OHM/SQ
5. All dimensions are in mm, unless otherwise specified.

M0168-01

PACKAGING INFORMATION

Orderable Device	Status (1)	Package Type	Package Drawing	Pins	Package Qty	Eco Plan (2)	Lead finish/ Ball material (6)	MSL Peak Temp (3)	Op Temp (°C)	Device Marking (4/5)	Samples
CSD25310Q2	ACTIVE	WSON	DQK	6	3000	RoHS & Green	NIPDAU SN	Level-1-260C-UNLIM	-55 to 150	2530	Samples
CSD25310Q2T	ACTIVE	WSON	DQK	6	250	RoHS & Green	SN	Level-1-260C-UNLIM	-55 to 150	2530	Samples

(1) The marketing status values are defined as follows:

ACTIVE: Product device recommended for new designs.

LIFEBUY: TI has announced that the device will be discontinued, and a lifetime-buy period is in effect.

NRND: Not recommended for new designs. Device is in production to support existing customers, but TI does not recommend using this part in a new design.

PREVIEW: Device has been announced but is not in production. Samples may or may not be available.

OBSOLETE: TI has discontinued the production of the device.

(2) **RoHS:** TI defines "RoHS" to mean semiconductor products that are compliant with the current EU RoHS requirements for all 10 RoHS substances, including the requirement that RoHS substance do not exceed 0.1% by weight in homogeneous materials. Where designed to be soldered at high temperatures, "RoHS" products are suitable for use in specified lead-free processes. TI may reference these types of products as "Pb-Free".

RoHS Exempt: TI defines "RoHS Exempt" to mean products that contain lead but are compliant with EU RoHS pursuant to a specific EU RoHS exemption.

Green: TI defines "Green" to mean the content of Chlorine (Cl) and Bromine (Br) based flame retardants meet JS709B low halogen requirements of <=1000ppm threshold. Antimony trioxide based flame retardants must also meet the <=1000ppm threshold requirement.

(3) MSL, Peak Temp. - The Moisture Sensitivity Level rating according to the JEDEC industry standard classifications, and peak solder temperature.

(4) There may be additional marking, which relates to the logo, the lot trace code information, or the environmental category on the device.

(5) Multiple Device Markings will be inside parentheses. Only one Device Marking contained in parentheses and separated by a "~" will appear on a device. If a line is indented then it is a continuation of the previous line and the two combined represent the entire Device Marking for that device.

(6) Lead finish/Ball material - Orderable Devices may have multiple material finish options. Finish options are separated by a vertical ruled line. Lead finish/Ball material values may wrap to two lines if the finish value exceeds the maximum column width.

Important Information and Disclaimer:The information provided on this page represents TI's knowledge and belief as of the date that it is provided. TI bases its knowledge and belief on information provided by third parties, and makes no representation or warranty as to the accuracy of such information. Efforts are underway to better integrate information from third parties. TI has taken and continues to take reasonable steps to provide representative and accurate information but may not have conducted destructive testing or chemical analysis on incoming materials and chemicals. TI and TI suppliers consider certain information to be proprietary, and thus CAS numbers and other limited information may not be available for release.

In no event shall TI's liability arising out of such information exceed the total purchase price of the TI part(s) at issue in this document sold by TI to Customer on an annual basis.

重要声明和免责声明

TI“按原样”提供技术和可靠性数据（包括数据表）、设计资源（包括参考设计）、应用或其他设计建议、网络工具、安全信息和其他资源，不保证没有瑕疵且不做任何明示或暗示的担保，包括但不限于对适销性、某特定用途方面的适用性或不侵犯任何第三方知识产权的暗示担保。

这些资源可供使用 TI 产品进行设计的熟练开发人员使用。您将自行承担以下全部责任：(1) 针对您的应用选择合适的 TI 产品，(2) 设计、验证并测试您的应用，(3) 确保您的应用满足相应标准以及任何其他功能安全、信息安全、监管或其他要求。

这些资源如有变更，恕不另行通知。TI 授权您仅可将这些资源用于研发本资源所述的 TI 产品的应用。严禁对这些资源进行其他复制或展示。您无权使用任何其他 TI 知识产权或任何第三方知识产权。您应全额赔偿因在这些资源的使用中对 TI 及其代表造成的任何索赔、损害、成本、损失和债务，TI 对此概不负责。

TI 提供的产品受 [TI 的销售条款](#) 或 [ti.com](#) 上其他适用条款/TI 产品随附的其他适用条款的约束。TI 提供这些资源并不会扩展或以其他方式更改 TI 针对 TI 产品发布的适用的担保或担保免责声明。

TI 反对并拒绝您可能提出的任何其他或不同的条款。

邮寄地址：Texas Instruments, Post Office Box 655303, Dallas, Texas 75265

Copyright © 2022，德州仪器 (TI) 公司