

# DRV5015-Q1 汽车低电压高灵敏度数字锁存器霍尔效应传感器

## 1 特性

- 适用于汽车 应用
- 具有符合 AEC-Q100 标准的下列结果：
  - 器件温度等级 0:  $-40^{\circ}\text{C}$  至  $150^{\circ}\text{C}$  的环境工作温度范围
  - 器件 HBM ESD 分类等级 H3A
  - 器件 CDM ESD 分类等级 C6
- 数字锁存器霍尔效应传感器
- 高磁性灵敏度：
  - DRV5015A1-Q1:  $\pm 0.7\text{mT}$  (典型值)
  - DRV5015A2-Q1:  $\pm 1.8\text{mT}$  (典型值)
  - DRV5015A3-Q1:  $\pm 1.8\text{mT}$  (反相, 典型值)
- 集成迟滞
- 30kHz 高速感应带宽
- 2.5V 至 5.5V 工作  $V_{\text{CC}}$  范围
- 开漏输出, 输出电流高达 20mA

## 2 应用

- 无刷直流电机传感器：
  - 燃油泵
  - 电子助力转向
  - 电动天窗
  - 车窗
  - 滑动门
- 增量旋转编码：
  - 电机速度 (转速计)
  - 机械行程
  - 流体测量
  - 人机界面旋钮
  - 轮速

## 3 说明

DRV5015-Q1 是一款低电压数字锁存器霍尔效应传感器, 专为高速和高温电机 应用。该器件由 2.5V 至 5.5V 的电源供电, 可以检测磁通量密度并根据预定义的磁性阈值显示数字输出。

必须交换北极和南极磁极才能切换输出, 集成的磁滞能够提供稳定可靠的切换。

该器件具有两个磁性阈值选项和一个反相输出选项。高磁性灵敏度可提供低成本磁体选择和组件放置灵活性。

该器件在  $-40^{\circ}\text{C}$  至  $+150^{\circ}\text{C}$  的宽环境温度范围内能够保持稳定一致的优异性能。

器件信息<sup>(1)</sup>

器件型号	封装	封装尺寸 (标称值)
DRV5015-Q1	SOT-23 (3)	2.92mm × 1.30mm

(1) 如需了解所有可用封装, 请参阅数据表末尾的封装选项附录。

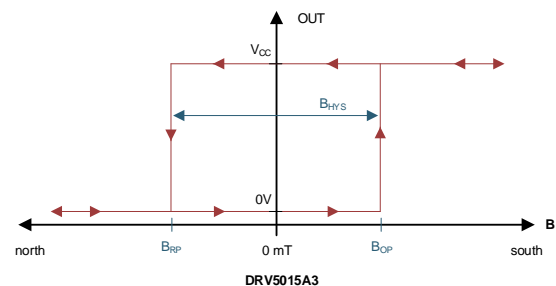
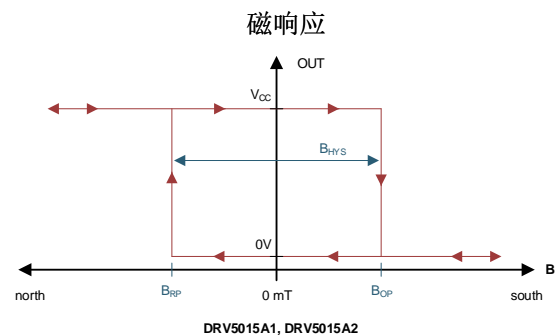

典型原理图

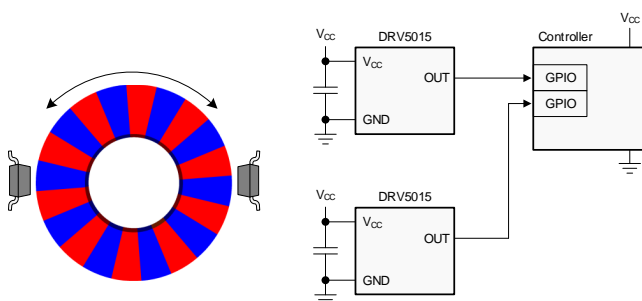

## 目录

1	特性 .....	1	7.4	Device Functional Modes.....	12
2	应用 .....	1	<b>8</b>	<b>Application and Implementation .....</b>	<b>13</b>
3	说明 .....	1	8.1	Application Information.....	13
4	修订历史记录 .....	2	8.2	Typical Applications .....	13
<b>5</b>	<b>Pin Configuration and Functions .....</b>	<b>3</b>	8.3	What to Do and What Not to Do .....	16
<b>6</b>	<b>Specifications.....</b>	<b>3</b>	<b>9</b>	<b>Power Supply Recommendations.....</b>	<b>17</b>
6.1	Absolute Maximum Ratings .....	3	<b>10</b>	<b>Layout.....</b>	<b>17</b>
6.2	ESD Ratings.....	3	10.1	Layout Guidelines .....	17
6.3	Recommended Operating Conditions.....	4	10.2	Layout Example .....	17
6.4	Thermal Information .....	4	<b>11</b>	<b>器件和文档支持 .....</b>	<b>18</b>
6.5	Electrical Characteristics.....	4	11.1	文档支持.....	18
6.6	Magnetic Characteristics.....	4	11.2	接收文档更新通知 .....	18
6.7	Typical Characteristics .....	5	11.3	社区资源 .....	18
<b>7</b>	<b>Detailed Description .....</b>	<b>7</b>	11.4	商标 .....	18
7.1	Overview .....	7	11.5	静电放电警告.....	18
7.2	Functional Block Diagram .....	7	11.6	术语表 .....	18
7.3	Feature Description.....	7	<b>12</b>	<b>机械、封装和可订购信息.....</b>	<b>18</b>

## 4 修订历史记录

Changes from Revision A (November 2018) to Revision B	Page
• Changed output voltage max value from $V_{CC} + 0.3\text{ V}$ to 6.0 V in the <i>Absolute Maximum Ratings</i> table .....	3
• Changed $T_A = -40^\circ\text{C}$ to $+150^\circ\text{C}$ min and max values in <i>Magnetic Characteristics</i> table .....	4
• Added $T_A = -40^\circ\text{C}$ to $+125^\circ\text{C}$ limits to the <i>Magnetic Characteristics</i> table .....	4

Changes from Original (September 2018) to Revision A	Page
• 已更改 maximum temperature inside the motor from $125^\circ\text{C}$ to $150^\circ\text{C}$ in Table 1 .....	13

## 5 Pin Configuration and Functions

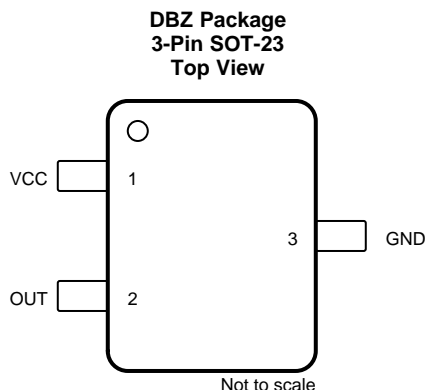

### Pin Functions

PIN		TYPE	DESCRIPTION
NAME	NO.		
GND	3	Ground	Ground reference.
OUT	2	Output	Open-drain output.
VCC	1	Power supply	2.5-V to 5.5-V power supply. Connect a ceramic capacitor with a value of at least 0.01 $\mu$ F between VCC and ground.

## 6 Specifications

### 6.1 Absolute Maximum Ratings

over operating free-air temperature range (unless otherwise noted)<sup>(1)</sup>

		MIN	MAX	UNIT
$V_{CC}$	Power supply voltage	-0.3	6.0	V
$V_{OUT}$	Output voltage	-0.3	6.0	V
$I_{OUT}$	Output current		30	mA
$B_{MAX}$	Magnetic flux density		Unlimited	T
$T_J$	Operating junction temperature	-40	170	$^{\circ}$ C
$T_{stg}$	Storage temperature	-65	150	$^{\circ}$ C

(1) Stresses beyond those listed under Absolute Maximum Ratings may cause permanent damage to the device. These are stress ratings only, which do not imply functional operation of the device at these or any other conditions beyond those indicated under Recommended Operating Conditions. Exposure to absolute-maximum-rated conditions for extended periods may affect device reliability.

### 6.2 ESD Ratings

over operating free-air temperature range (unless otherwise noted)

			VALUE	UNIT
$V_{(ESD)}$	Electrostatic discharge	Human body model (HBM), per AEC Q100-002 <sup>(1)</sup>	$\pm$ 5000	V
		Charged device model (CDM), per AEC Q100-011	$\pm$ 1500	

(1) AEC Q100-002 indicates that HBM stressing shall be in accordance with the ANSI/ESDA/JEDEC JS-001 specification.

### 6.3 Recommended Operating Conditions

over operating free-air temperature range (unless otherwise noted)

		MIN	MAX	UNIT
V <sub>CC</sub>	Power supply voltage	2.5	5.5	V
V <sub>OUT</sub>	Output pin voltage	0	5.5	V
I <sub>OUT</sub>	Output sinking current	0	20	mA
T <sub>A</sub>	Operating ambient temperature	−40	150	°C

### 6.4 Thermal Information

THERMAL METRIC <sup>(1)</sup>		DRV5015-Q1	UNIT
		SOT-23 (DBZ)	
		3 PINS	
R <sub>θJA</sub>	Junction-to-ambient thermal resistance	356	°C/W
R <sub>θJC(top)</sub>	Junction-to-case (top) thermal resistance	128	°C/W
R <sub>θJB</sub>	Junction-to-board thermal resistance	94	°C/W
Y <sub>JT</sub>	Junction-to-top characterization parameter	11.4	°C/W
Y <sub>JB</sub>	Junction-to-board characterization parameter	92	°C/W

 (1) For information about traditional and new thermal metrics, see the [Semiconductor and IC Package Thermal Metrics application report](#).

### 6.5 Electrical Characteristics

 at V<sub>CC</sub> = 2.5 V to 5.5 V, over operating free-air temperature range (unless otherwise noted)

PARAMETER		TEST CONDITION	MIN	TYP	MAX	UNIT
I <sub>CC</sub>	Operating supply current			2.3	2.8	mA
t <sub>ON</sub>	Power-on time			40	70	μs
t <sub>d</sub>	Propagation delay time <sup>(1)</sup>	B = B <sub>RP</sub> − 10 mT to B <sub>OP</sub> + 10 mT in 1 μs		13	25	μs
I <sub>OZ</sub>	High-impedance output leakage current	5.5 V applied to OUT, while OUT is high-impedance			100	nA
V <sub>OL</sub>	Low-level output voltage	I <sub>OUT</sub> = 20 mA		0.15	0.4	V

 (1) See the [Propagation Delay](#) section for more information.

### 6.6 Magnetic Characteristics

 at V<sub>CC</sub> = 2.5 V to 5.5 V, over operating free-air temperature range (unless otherwise noted)

PARAMETER		TEST CONDITION	MIN	TYP	MAX	UNIT
<b>DRV5015A1-Q1, DRV5015A2-Q1, DRV5015A3-Q1</b>						
f <sub>BW</sub>	Sensing bandwidth		20	30		kHz
<b>DRV5015A1-Q1</b>						
B <sub>OP</sub>	Magnetic threshold operate point	T <sub>A</sub> = −40°C to +125°C	−0.2	0.7	2.0	mT
		T <sub>A</sub> = −40°C to +150°C	−0.5	0.7	2.9	mT
B <sub>RP</sub>	Magnetic threshold release point	T <sub>A</sub> = −40°C to +125°C	−2.0	−0.7	0.2	mT
		T <sub>A</sub> = −40°C to +150°C	−2.9	−0.7	0.5	mT
B <sub>HYS</sub>	Magnetic hysteresis:  B <sub>OP</sub> − B <sub>RP</sub>	T <sub>A</sub> = −40°C to +125°C	0.35	1.4		mT
B <sub>HYS</sub>	Magnetic hysteresis:  B <sub>OP</sub> − B <sub>RP</sub>	T <sub>A</sub> = −40°C to +150°C	0.3	1.4		mT
<b>DRV5015A2-Q1, DRV5015A3-Q1</b>						
B <sub>OP</sub>	Magnetic threshold operate point	T <sub>A</sub> = −40°C to +125°C	0.5	1.8	3.7	mT
		T <sub>A</sub> = −40°C to +150°C	0.2	1.8	4.5	mT
B <sub>RP</sub>	Magnetic threshold release point	T <sub>A</sub> = −40°C to +125°C	−3.7	−1.8	−0.5	mT
		T <sub>A</sub> = −40°C to +150°C	−4.5	−1.8	−0.2	mT
B <sub>HYS</sub>	Magnetic hysteresis:  B <sub>OP</sub> − B <sub>RP</sub>	T <sub>A</sub> = −40°C to +125°C	2.3	3.6		mT
B <sub>HYS</sub>	Magnetic hysteresis:  B <sub>OP</sub> − B <sub>RP</sub>	T <sub>A</sub> = −40°C to +150°C	1.75	3.6		mT

## 6.7 Typical Characteristics

at  $T_A = 25^\circ\text{C}$  typical (unless otherwise noted)

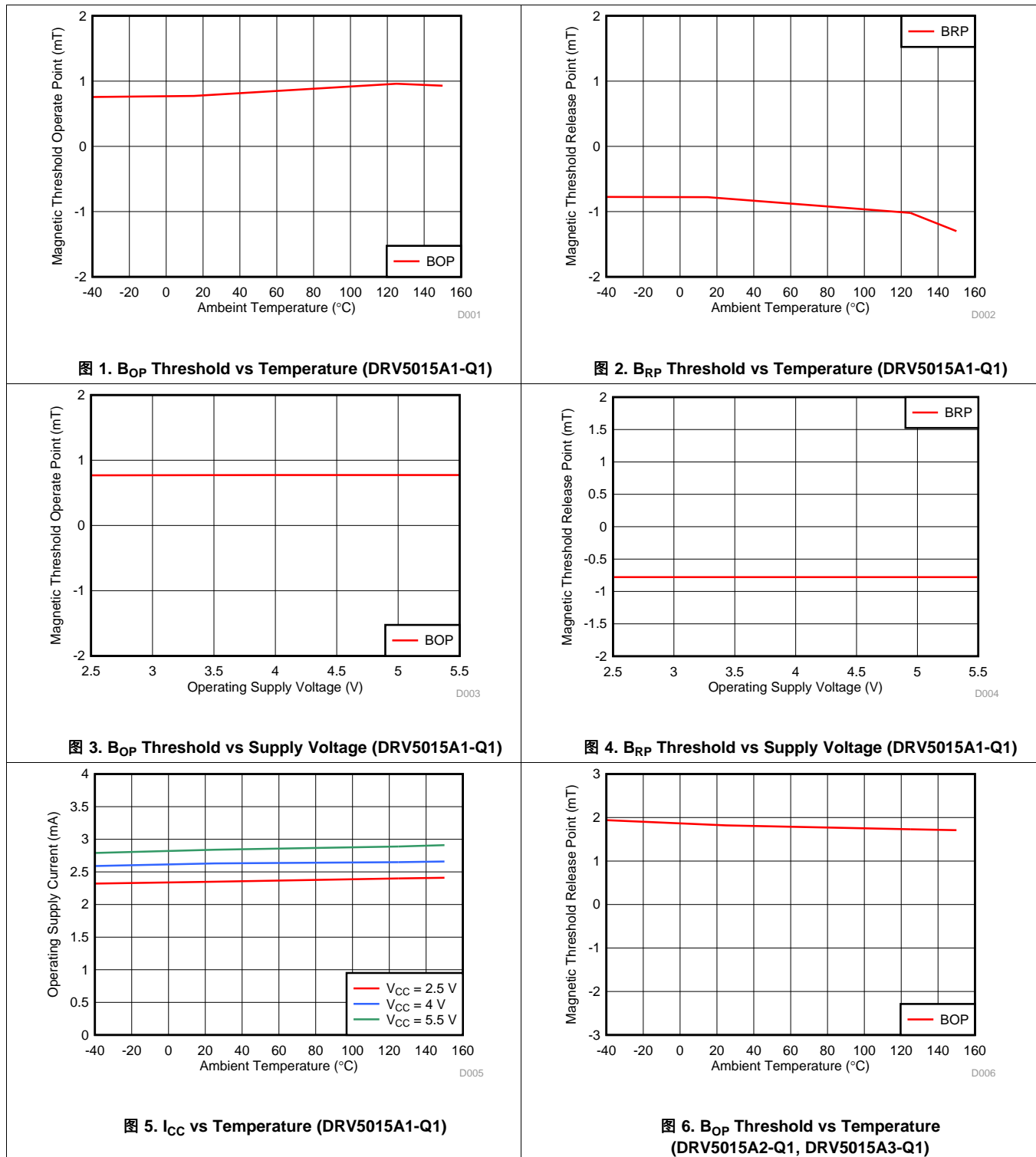

Typical Characteristics (接下页)

at  $T_A = 25^\circ\text{C}$  typical (unless otherwise noted)



图 7.  $B_{RP}$  Threshold vs Temperature (DRV5015A2-Q1, DRV5015A3-Q1)



图 8.  $B_{OP}$  Threshold vs Supply Voltage (DRV5015A2-Q1, DRV5015A3-Q1)

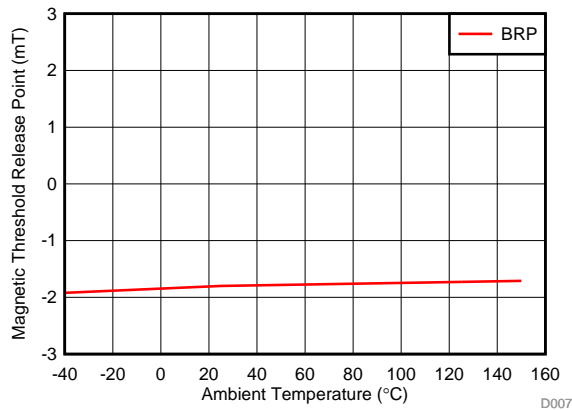

图 9.  $B_{RP}$  Threshold vs Supply Voltage (DRV5015A2-Q1, DRV5015A3-Q1)

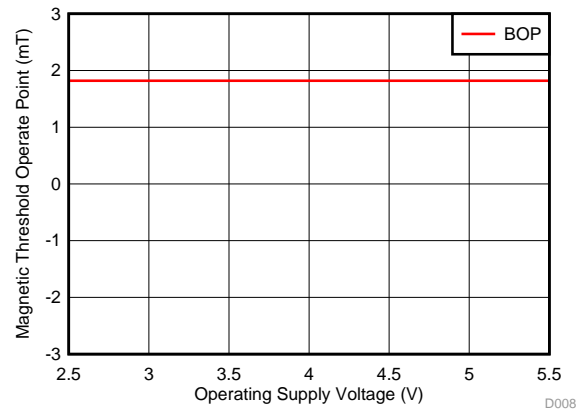

图 10.  $I_{CC}$  vs Temperature (DRV5015A2-Q1, DRV5015A3-Q1)

## 7 Detailed Description

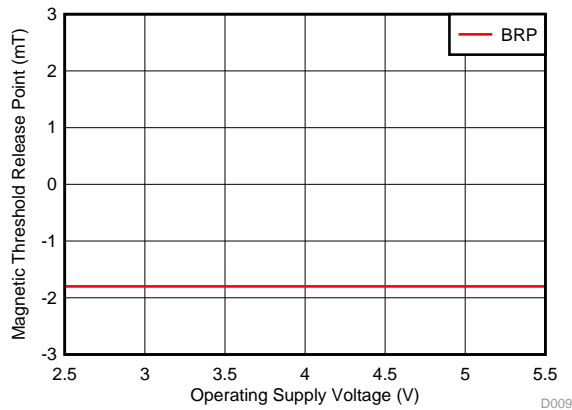
### 7.1 Overview

The DRV5015-Q1 is a magnetic sensor with a digital output that latches the most recent pole measured. During power-up, in the absence of an external magnetic field, the DRV5015A1-Q1 and DRV5015A2-Q1 default to a low output state and the DRV5015A3-Q1 defaults to a high output state. Applying a south magnetic pole near the top of the package causes the DRV5015A1-Q1 and DRV5015A2-Q1 output to drive low, whereas a north magnetic pole causes this output to drive high. Applying a south magnetic pole near the top of the package causes the DRV5015A3-Q1 output to drive high, whereas a north magnetic pole causes this output to drive low. The absence of a magnetic field causes the output to continue to drive the current state, whether low or high.

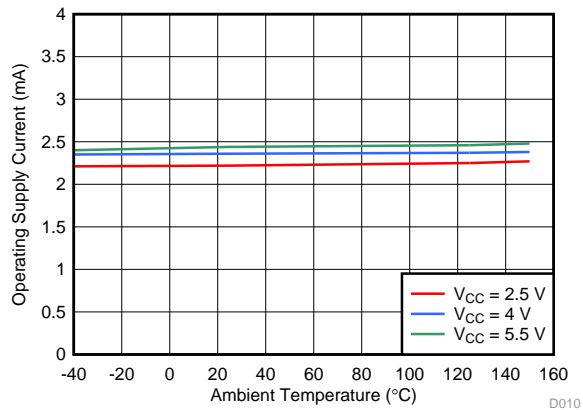
The device integrates a Hall effect element, analog signal conditioning, offset cancellation circuits, amplifiers, and comparators. These features provide stable performance across a wide temperature range and resistance to mechanical stress.

### 7.2 Functional Block Diagram

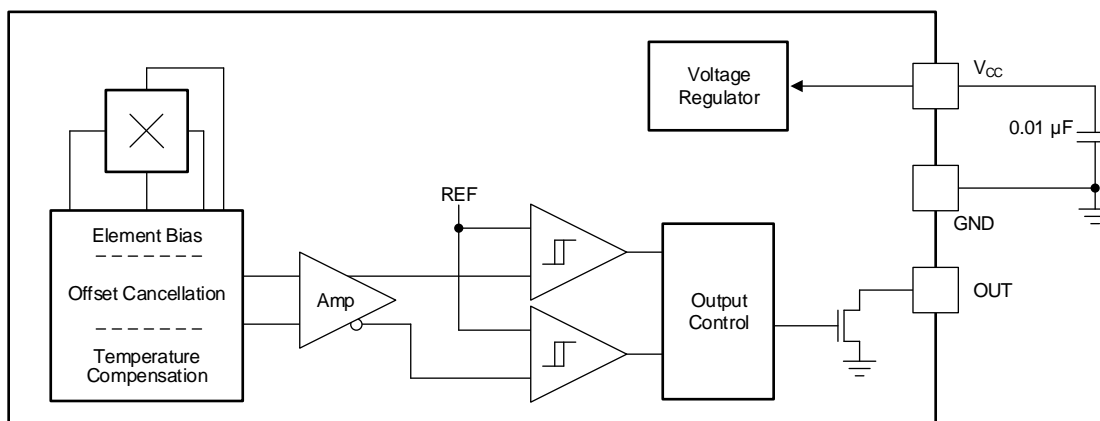

### 7.3 Feature Description

#### 7.3.1 Magnetic Flux Direction

As shown in [图 11](#), the DRV5015-Q1 is sensitive to the magnetic field component that is perpendicular to the top of the package.



图 11. Direction of Sensitivity

**Feature Description (接下页)**

Magnetic flux that travels from the bottom to the top of the package is considered positive in this document. This condition exists when a south magnetic pole is near the top of the package. Magnetic flux that travels from the top to the bottom of the package is considered negative. 图 12 shows the flux direction polarity.

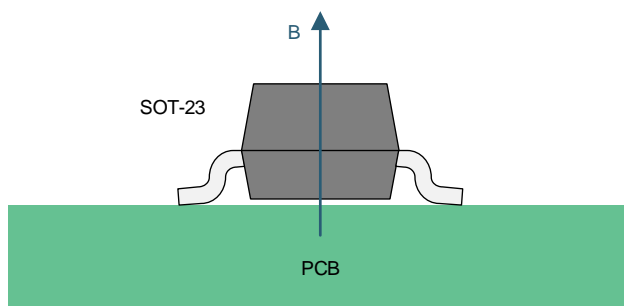

图 12. Flux Direction Polarity



## Feature Description (接下页)

### 7.3.2 Magnetic Response

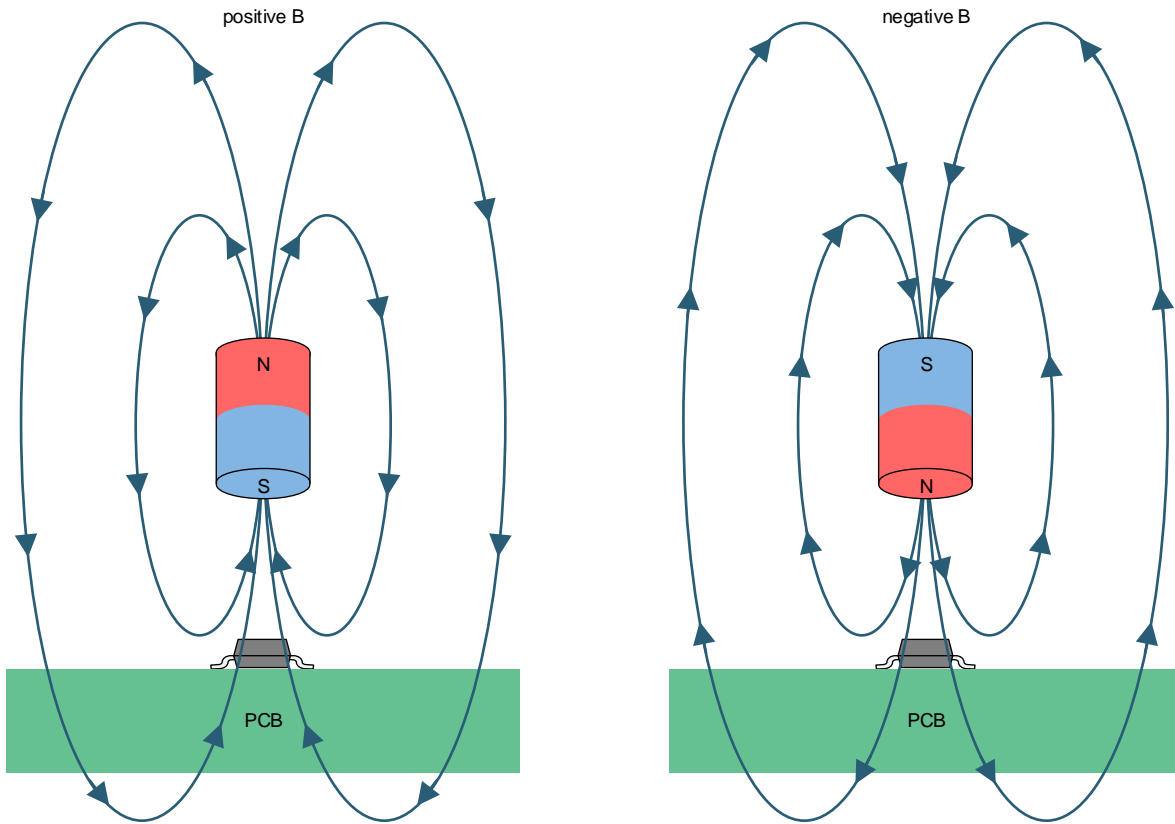
图 13 shows the device output response to stimulus and hysteresis.



图 13. Device Output Response to Stimulus

## Feature Description (接下页)

### 7.3.3 Output Driver

图 14 显示了 DRV5015-Q1 开漏输出结构。开漏输出提供了灵活性，通过启用系统设计师可以接口到宽范围的 GPIO 终止电压。C1 代表了 GPIO 的输入电容。R1 代表了连接到终止电压， $V_{PULL\_UP}$  的拉上电阻。最大允许的  $V_{PULL\_UP}$  值是 5.5 V。R1 的值必须在考虑系统速度和拉上电阻的功耗后选择。

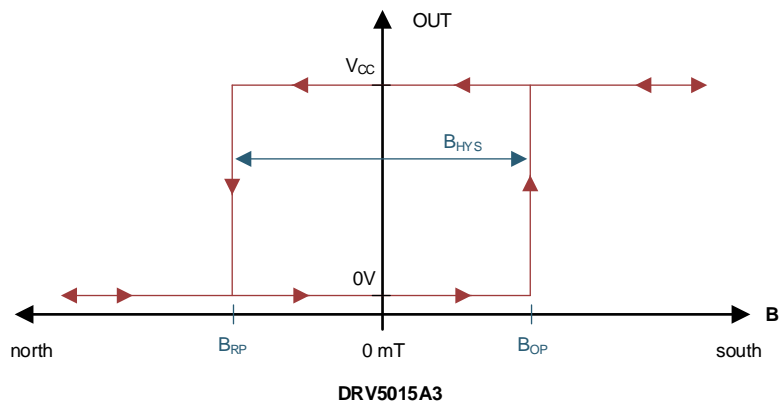
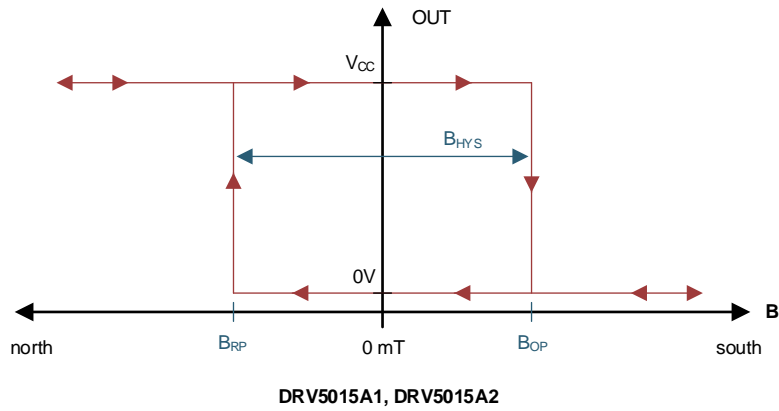

图 14. Open-Drain Output (Simplified)

### 7.3.4 Power-On Time

图 15 显示，在  $V_{CC}$  电压施加后，DRV5015-Q1 测量磁场并在  $t_{ON}$  时间内设置输出。

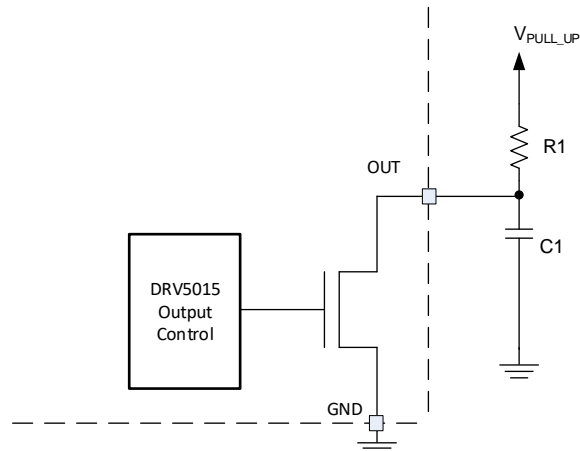

图 15.  $t_{ON}$  Definition

## Feature Description (接下页)

### 7.3.5 Hall Element Location

The sensing element inside the device is in the center of both packages when viewed from the top. 图 16 shows the tolerances and side-view dimensions.

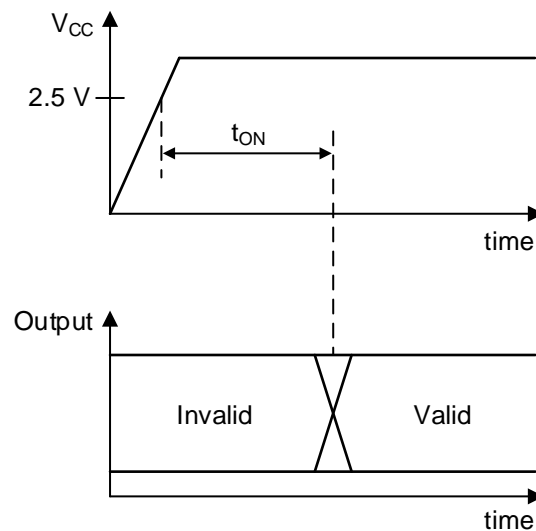

图 16. Hall Element Location

## Feature Description (接下页)

### 7.3.6 Propagation Delay

The DRV5015-Q1 samples the Hall element at a nominal sampling interval of every 16.67  $\mu\text{s}$  to detect the presence of a magnetic north or south pole. At each sampling point, the device takes the average of the current sampled value and immediately preceding sampled value of the magnetic field. If this average value crosses the  $B_{OP}$  or  $B_{RP}$  threshold, the device output changes to the corresponding state as defined by the [Overview](#) section.

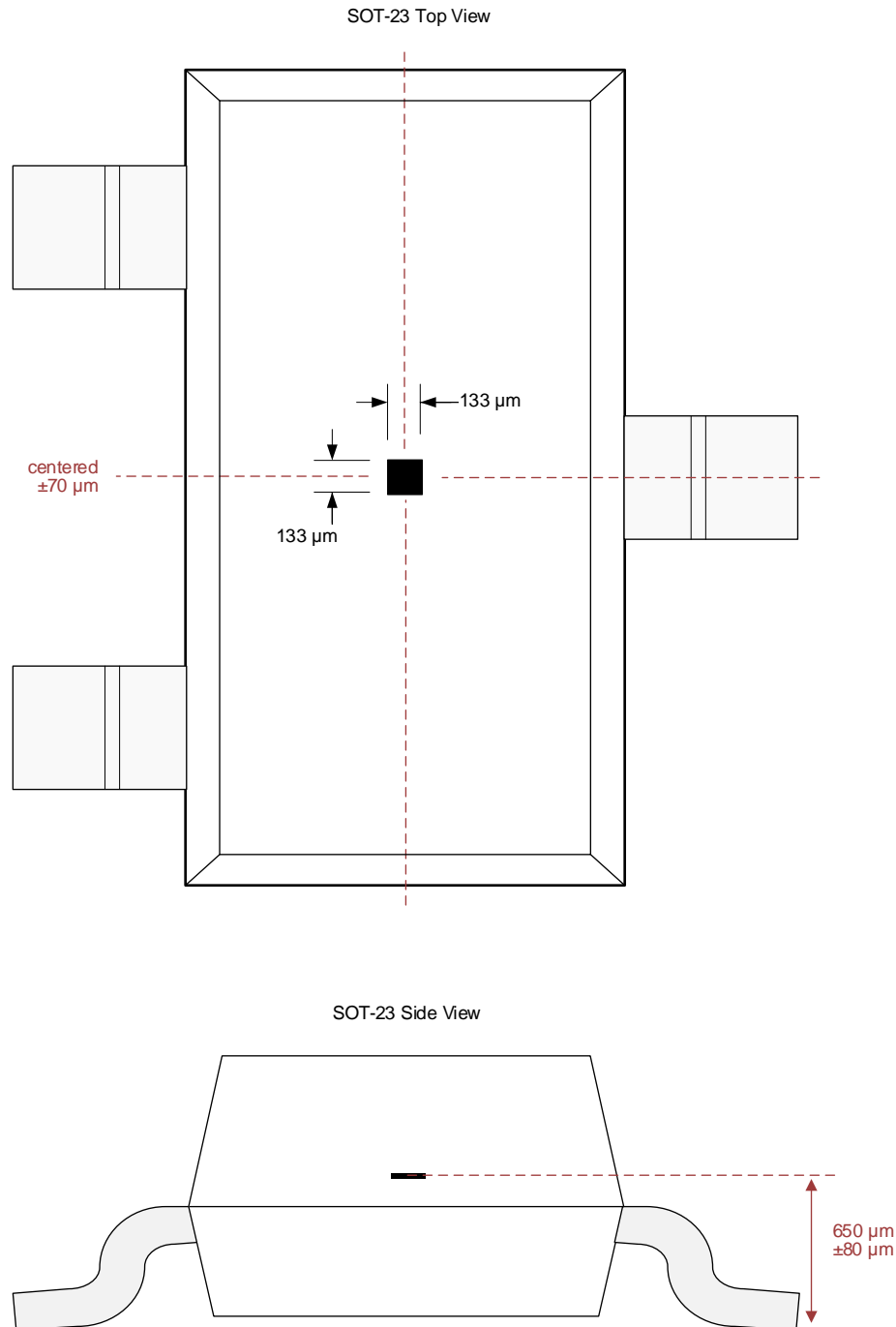
图 17 shows the DRV5015A1-Q1 propagation delay analysis in the proximity of a magnetic south pole. The Hall element of the DRV5015-Q1 experiences an increasing magnetic field as a magnetic south pole approaches near the device. At time  $t_2$ , the average magnetic field is  $(B_2 + B_1) / 2$ , which is below the  $B_{OP}$  threshold of the device. At time  $t_3$ , the actual magnetic field has crossed the  $B_{OP}$  threshold. However, the average  $(B_3 + B_2) / 2$  is still less than the  $B_{OP}$  threshold. As such, the device waits for next sample time,  $t_4$ , to start the output transition through the analog signal chain. The propagation delay,  $t_d$ , is measured as the delay from the time the magnetic field crosses the  $B_{OP}$  threshold to the time output transitions.



图 17. Propagation Delay

## 7.4 Device Functional Modes

The DRV5015-Q1 has one mode of operation that applies when the are met.

## 8 Application and Implementation

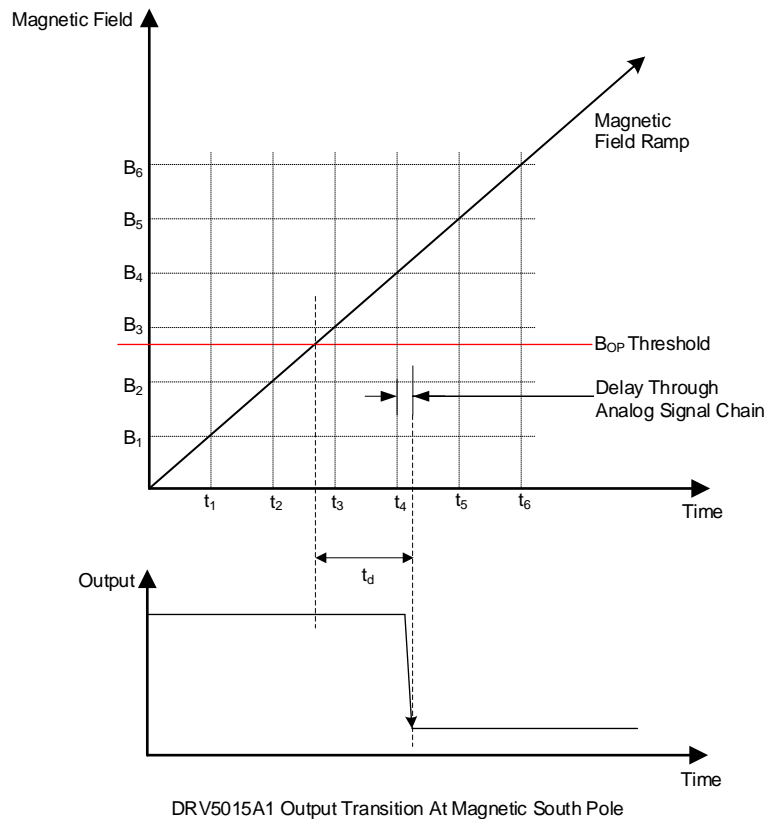
### 注

Information in the following applications sections is not part of the TI component specification, and TI does not warrant its accuracy or completeness. TI's customers are responsible for determining suitability of components for their purposes. Customers should validate and test their design implementation to confirm system functionality.

### 8.1 Application Information

The DRV5015-Q1 is ideal for use in rotary applications for brushless DC (BLDC) motor sensors or incremental rotary encoding.

For reliable functionality, the magnet must apply a flux density at the sensor greater than the corresponding maximum  $B_{OP}$  or  $B_{RP}$  numbers specified in the table. Add additional margin to account for mechanical tolerance, temperature effects, and magnet variation. Magnets generally produce weaker fields as temperature increases.

### 8.2 Typical Applications

#### 8.2.1 BLDC Motor Sensors Application



图 18. BLDC Motor System

#### 8.2.1.1 Design Requirements

Use the parameters listed in 表 1 for this design.

表 1. Design Parameters

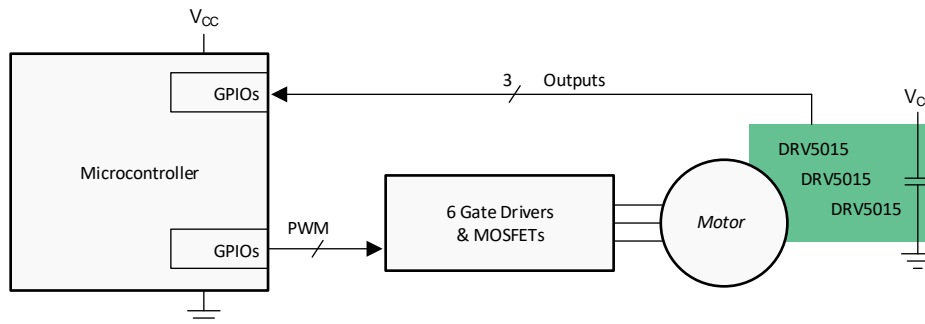
DESIGN PARAMETER	EXAMPLE VALUE
Number of motor phases	3
Motor RPM	15 kRPM
Number of magnet poles on the rotor	12
Magnetic material	Bonded neodymium
Maximum temperature inside the motor	150°C
Magnetic flux density peaks at the Hall sensors at maximum temperature	±11 mT
Hall sensor $V_{CC}$	5 V ± 10%

### 8.2.1.2 Detailed Design Procedure

Three-phase brushless DC motors often use three Hall effect latch devices to measure the electrical angle of the rotor and tell the controller how to drive the three wires. These wires connect to electromagnet windings, which generate magnetic fields that apply forces to the permanent magnets on the rotor.

Space the three Hall sensors across the printed-circuit board (PCB) so that these sensors are 120 electrical degrees apart. This configuration creates six 3-bit states with equal time duration for each electrical cycle, which consists of one north and one south magnetic pole. From the center of the motor axis, the number of degrees to space each sensor equals  $2 / [\textit{number of poles}] \times 120^\circ$ . In this design example, the first sensor is placed at  $0^\circ$ , the second sensor is placed  $20^\circ$  rotated, and the third sensor is placed  $40^\circ$  rotated. Alternatively, a  $3\times$  degree offset can be added or subtracted to any sensor, meaning that the third sensor can alternatively be placed at  $40^\circ - (3 \times 20^\circ) = -20^\circ$ .

### 8.2.1.3 Application Curve



图 19. Phase Voltages and Hall Signals for a 3-Phase BLDC Motor

## 8.2.2 Incremental Rotary Encoding Application

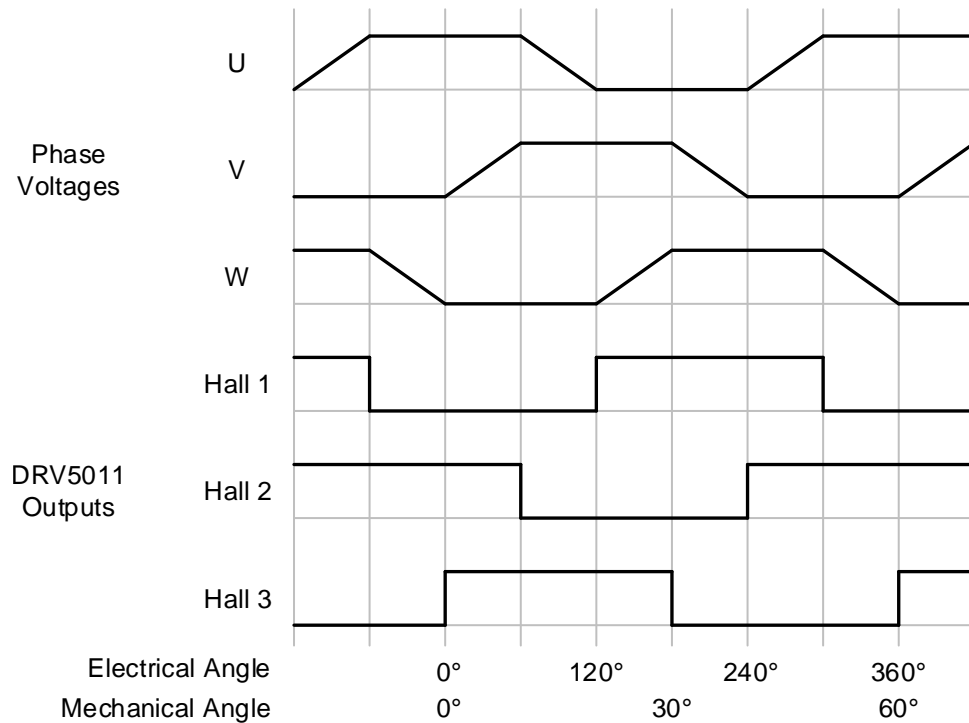

图 20. Incremental Rotary Encoding System

### 8.2.2.1 Design Requirements

Use the parameters listed in 表 2 for this design.

表 2. Design Parameters

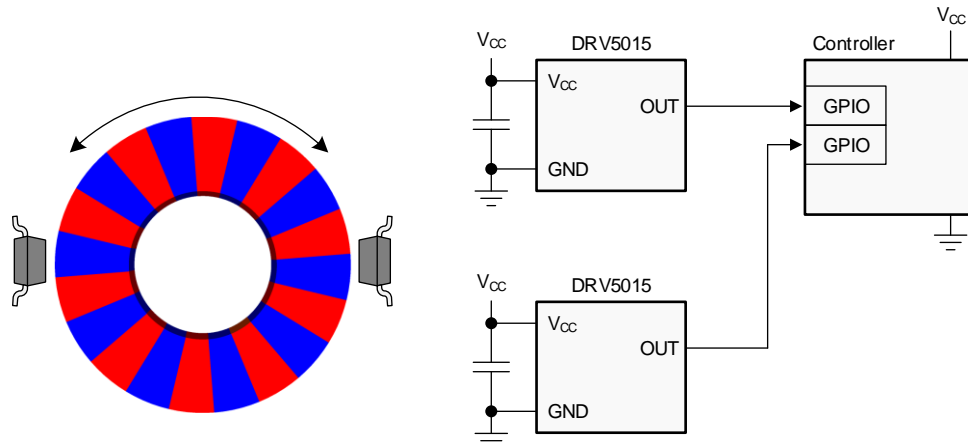
DESIGN PARAMETER	EXAMPLE VALUE
RPM range	45 kRPM
Number of magnet poles	8
Magnetic material	Ferrite
Air gap above the Hall sensors	2.5 mm
Magnetic flux density peaks at the Hall sensors at maximum temperature	$\pm 7$ mT

### 8.2.2.2 Detailed Design Procedure

Incremental encoders are used on knobs, wheels, motors, and flow meters to measure relative rotary movement. By attaching a ring magnet to the rotating component and placing a DRV5015-Q1 nearby, the sensor generates voltage pulses as the magnet turns. If directional information is also needed (clockwise versus counterclockwise), a second DRV5015-Q1 can be added with a phase offset, and then the order of transitions between the two signals describes the direction.

Creating this phase offset requires spacing the two sensors apart on the PCB, and an ideal 90° quadrature offset is attained when the sensors are separated by half the length of each magnet pole, plus any integer number of pole lengths. 图 20 shows this configuration because the sensors are 1.5 pole lengths apart. One of the sensors changes its output every  $360^\circ / 8 \text{ poles} / 2 \text{ sensors} = 22.5^\circ$  of rotation. For reference, the [TIDA-00480 TI Design Considerations Automotive Hall Sensor Rotary Encoder](#) uses a 66-pole magnet with changes every 2.7°.

The maximum rotational speed that can be measured is limited by the sensor bandwidth. Generally, the bandwidth must be faster than two times the number of poles per second. In this design example, the maximum speed is 45000 RPM, which involves 6000 poles per second. The DRV5015-Q1 sensing bandwidth is typically 30 kHz, which is five times the pole frequency. In systems where the sensor sampling rate is close to two times the number of poles per second, most of the samples measure a magnetic field that is significantly lower than the peak value, because the peaks only occur when the sensor and pole are perfectly aligned. In this case, add margin by applying a stronger magnetic field that has peaks significantly higher than the maximum  $B_{OP}$ .

### 8.2.2.3 Application Curve

Two signals in quadrature provide movement and direction information. 图 21 shows how each 2-bit state has unique adjacent 2-bit states for clockwise and counterclockwise.



图 21. Quadrature Output (2-Bit)

### 8.3 What to Do and What Not to Do

The Hall element is sensitive to magnetic fields that are perpendicular to the top of the package; therefore, the correct magnet orientation must be used for the sensor to detect the field. 图 22 shows correct and incorrect orientations when using a ring magnet.

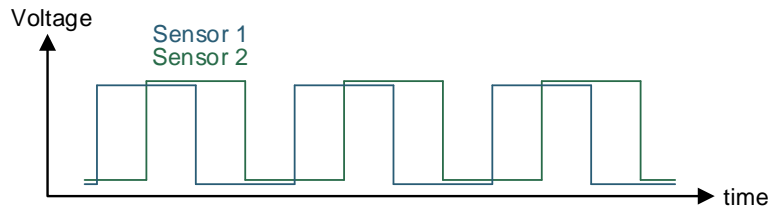

图 22. Correct and Incorrect Magnet Orientations



## 9 Power Supply Recommendations

The DRV5015-Q1 is powered from 2.5-V to 5.5-V DC power supplies. A decoupling capacitor close to the device must be used to provide local energy with minimal inductance. TI recommends using a ceramic capacitor with a value of at least 0.01  $\mu\text{F}$ .

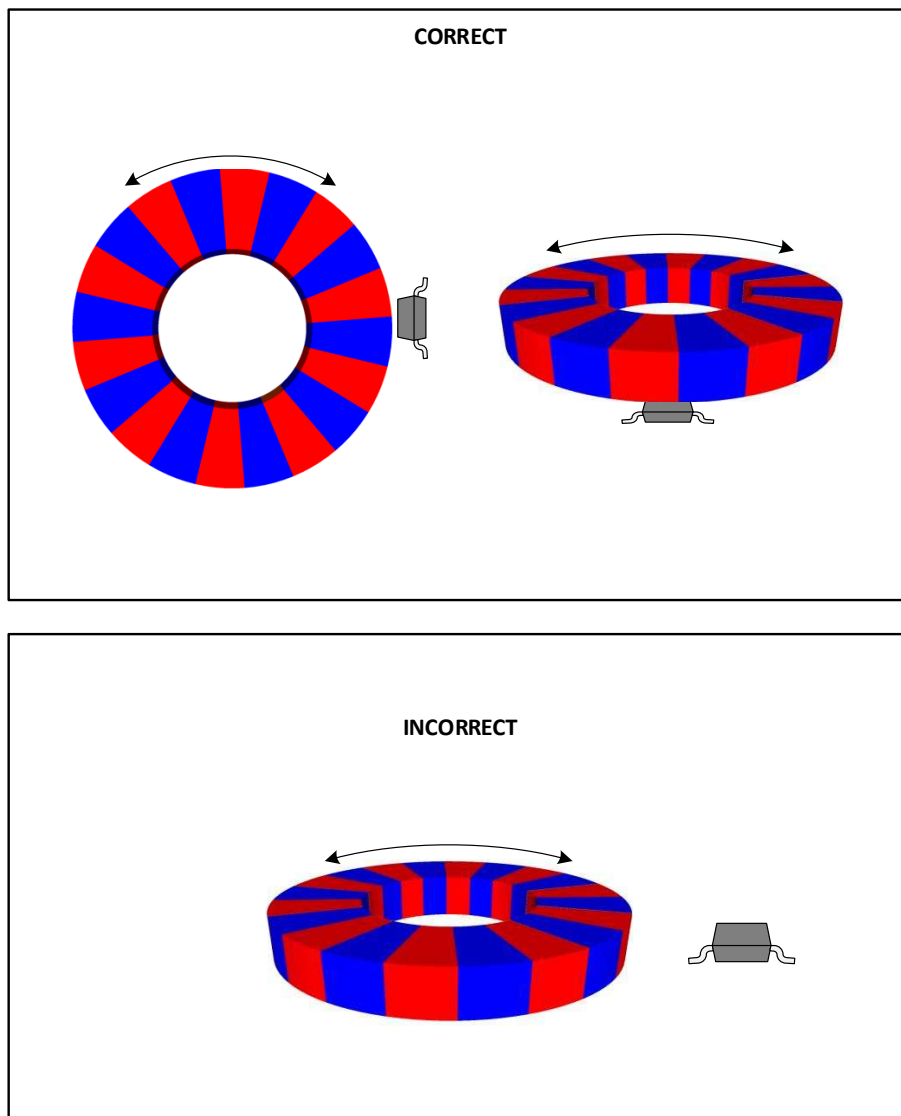
## 10 Layout

### 10.1 Layout Guidelines

Magnetic fields pass through most nonferromagnetic materials with no significant disturbance. Embedding Hall effect sensors within plastic or aluminum enclosures and sensing magnets on the outside is common practice. Magnetic fields also easily pass through most PCBs, which makes placing the magnet on the opposite side of the PCB possible.

### 10.2 Layout Example



图 23. Example Layout

## 11 器件和文档支持

### 11.1 文档支持

#### 11.1.1 相关文档

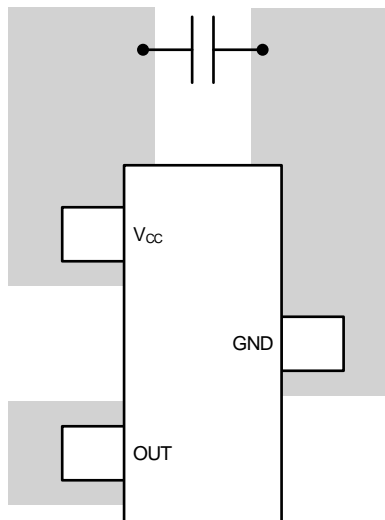
请参阅如下相关文档：

- 《TIDA-00480 TI 设计注意事项 - 汽车霍尔传感器旋转编码器》
- 《HALL-ADAPTER-EVM》用户指南

### 11.2 接收文档更新通知

要接收文档更新通知，请导航至 [TI.com.cn](http://TI.com.cn) 上的器件产品文件夹。单击右上角的 [通知我](#) 进行注册，即可每周接收产品信息更改摘要。有关更改的详细信息，请查看任何已修订文档中包含的修订历史记录。

### 11.3 社区资源

下列链接提供到 TI 社区资源的连接。链接的内容由各个分销商“按照原样”提供。这些内容并不构成 TI 技术规范，并且不一定反映 TI 的观点；请参阅 TI 的《[使用条款](#)》。

**TI E2E™ Online Community** *TI's Engineer-to-Engineer (E2E) Community*. Created to foster collaboration among engineers. At [e2e.ti.com](http://e2e.ti.com), you can ask questions, share knowledge, explore ideas and help solve problems with fellow engineers.

**Design Support** *TI's Design Support* Quickly find helpful E2E forums along with design support tools and contact information for technical support.

### 11.4 商标

E2E is a trademark of Texas Instruments.

All other trademarks are the property of their respective owners.

### 11.5 静电放电警告



ESD 可能会损坏该集成电路。德州仪器 (TI) 建议通过适当的预防措施处理所有集成电路。如果不遵守正确的处理措施和安装程序，可能会损坏集成电路。

ESD 的损坏小至导致微小的性能降级，大至整个器件故障。精密的集成电路可能更容易受到损坏，这是因为非常细微的参数更改都可能会导致器件与其发布的规格不相符。

### 11.6 术语表

**SLYZ022** — TI 术语表。

这份术语表列出并解释术语、缩写和定义。

## 12 机械、封装和可订购信息

以下页面包含机械、封装和可订购信息。这些信息是指定器件的最新可用数据。数据如有变更，恕不另行通知，且不会对此文档进行修订。如需获取此产品说明书的浏览器版本，请查阅左侧的导航栏。

## 重要声明和免责声明

TI 均以“原样”提供技术性数据（包括数据表）、设计资源（包括参考设计）、应用或其他设计建议、网络工具、安全信息和其他资源，不保证其中不含任何瑕疵，且不做任何明示或暗示的担保，包括但不限于对适销性、适合某特定用途或不侵犯任何第三方知识产权的暗示担保。

所述资源可供专业开发人员应用TI 产品进行设计使用。您将对以下行为独自承担全部责任：(1) 针对您的应用选择合适的TI 产品；(2) 设计、验证并测试您的应用；(3) 确保您的应用满足相应标准以及任何其他安全、安保或其他要求。所述资源如有变更，恕不另行通知。TI 对您使用所述资源的授权仅限于开发资源所涉及TI 产品的相关应用。除此之外不得复制或展示所述资源，也不提供其它TI 或任何第三方的知识产权授权许可。如因使用所述资源而产生任何索赔、赔偿、成本、损失及债务等，TI 对此概不负责，并且您须赔偿由此对TI 及其代表造成的损害。

TI 所提供产品均受TI 的销售条款 (<http://www.ti.com.cn/zh-cn/legal/termsofsale.html>) 以及ti.com.cn上或随附TI产品提供的其他可适用条款的约束。TI提供所述资源并不扩展或以其他方式更改TI 针对TI 产品所发布的可适用的担保范围或担保免责声明。

邮寄地址：上海市浦东新区世纪大道 1568 号中建大厦 32 楼，邮政编码：200122  
Copyright © 2019 德州仪器半导体技术（上海）有限公司

**PACKAGING INFORMATION**

Orderable Device	Status (1)	Package Type	Package Drawing	Pins	Package Qty	Eco Plan (2)	Lead finish/ Ball material (6)	MSL Peak Temp (3)	Op Temp (°C)	Device Marking (4/5)	Samples
DRV5015A1EDBZRQ1	ACTIVE	SOT-23	DBZ	3	3000	RoHS & Green	SN	Level-1-260C-UNLIM	-40 to 150	151Z	<a href="#">Samples</a>
DRV5015A2EDBZRQ1	ACTIVE	SOT-23	DBZ	3	3000	RoHS & Green	SN	Level-1-260C-UNLIM	-40 to 150	152Z	<a href="#">Samples</a>
DRV5015A3EDBZRQ1	ACTIVE	SOT-23	DBZ	3	3000	RoHS & Green	SN	Level-1-260C-UNLIM	-40 to 150	153Z	<a href="#">Samples</a>

(1) The marketing status values are defined as follows:

**ACTIVE:** Product device recommended for new designs.

**LIFEBUY:** TI has announced that the device will be discontinued, and a lifetime-buy period is in effect.

**NRND:** Not recommended for new designs. Device is in production to support existing customers, but TI does not recommend using this part in a new design.

**PREVIEW:** Device has been announced but is not in production. Samples may or may not be available.

**OBSOLETE:** TI has discontinued the production of the device.

(2) **RoHS:** TI defines "RoHS" to mean semiconductor products that are compliant with the current EU RoHS requirements for all 10 RoHS substances, including the requirement that RoHS substance do not exceed 0.1% by weight in homogeneous materials. Where designed to be soldered at high temperatures, "RoHS" products are suitable for use in specified lead-free processes. TI may reference these types of products as "Pb-Free".

**RoHS Exempt:** TI defines "RoHS Exempt" to mean products that contain lead but are compliant with EU RoHS pursuant to a specific EU RoHS exemption.

**Green:** TI defines "Green" to mean the content of Chlorine (Cl) and Bromine (Br) based flame retardants meet JS709B low halogen requirements of <=1000ppm threshold. Antimony trioxide based flame retardants must also meet the <=1000ppm threshold requirement.

(3) MSL, Peak Temp. - The Moisture Sensitivity Level rating according to the JEDEC industry standard classifications, and peak solder temperature.

(4) There may be additional marking, which relates to the logo, the lot trace code information, or the environmental category on the device.

(5) Multiple Device Markings will be inside parentheses. Only one Device Marking contained in parentheses and separated by a "~" will appear on a device. If a line is indented then it is a continuation of the previous line and the two combined represent the entire Device Marking for that device.

(6) Lead finish/Ball material - Orderable Devices may have multiple material finish options. Finish options are separated by a vertical ruled line. Lead finish/Ball material values may wrap to two lines if the finish value exceeds the maximum column width.

**Important Information and Disclaimer:**The information provided on this page represents TI's knowledge and belief as of the date that it is provided. TI bases its knowledge and belief on information provided by third parties, and makes no representation or warranty as to the accuracy of such information. Efforts are underway to better integrate information from third parties. TI has taken and continues to take reasonable steps to provide representative and accurate information but may not have conducted destructive testing or chemical analysis on incoming materials and chemicals. TI and TI suppliers consider certain information to be proprietary, and thus CAS numbers and other limited information may not be available for release.

In no event shall TI's liability arising out of such information exceed the total purchase price of the TI part(s) at issue in this document sold by TI to Customer on an annual basis.

## TAPE AND REEL INFORMATION



### QUADRANT ASSIGNMENTS FOR PIN 1 ORIENTATION IN TAPE



\*All dimensions are nominal

Device	Package Type	Package Drawing	Pins	SPQ	Reel Diameter (mm)	Reel Width W1 (mm)	A0 (mm)	B0 (mm)	K0 (mm)	P1 (mm)	W (mm)	Pin1 Quadrant
DRV5015A1EDBZRQ1	SOT-23	DBZ	3	3000	178.0	9.0	3.15	2.77	1.22	4.0	8.0	Q3
DRV5015A2EDBZRQ1	SOT-23	DBZ	3	3000	178.0	9.0	3.15	2.77	1.22	4.0	8.0	Q3
DRV5015A3EDBZRQ1	SOT-23	DBZ	3	3000	178.0	9.0	3.15	2.77	1.22	4.0	8.0	Q3

**TAPE AND REEL BOX DIMENSIONS**

\*All dimensions are nominal

Device	Package Type	Package Drawing	Pins	SPQ	Length (mm)	Width (mm)	Height (mm)
DRV5015A1EDBZRQ1	SOT-23	DBZ	3	3000	180.0	180.0	18.0
DRV5015A2EDBZRQ1	SOT-23	DBZ	3	3000	180.0	180.0	18.0
DRV5015A3EDBZRQ1	SOT-23	DBZ	3	3000	180.0	180.0	18.0

## GENERIC PACKAGE VIEW

**DBZ 3**

**SOT-23 - 1.12 mm max height**

SMALL OUTLINE TRANSISTOR



Images above are just a representation of the package family, actual package may vary.  
Refer to the product data sheet for package details.

4203227/C



DBZ0003A



# PACKAGE OUTLINE

SOT-23 - 1.12 mm max height

SMALL OUTLINE TRANSISTOR

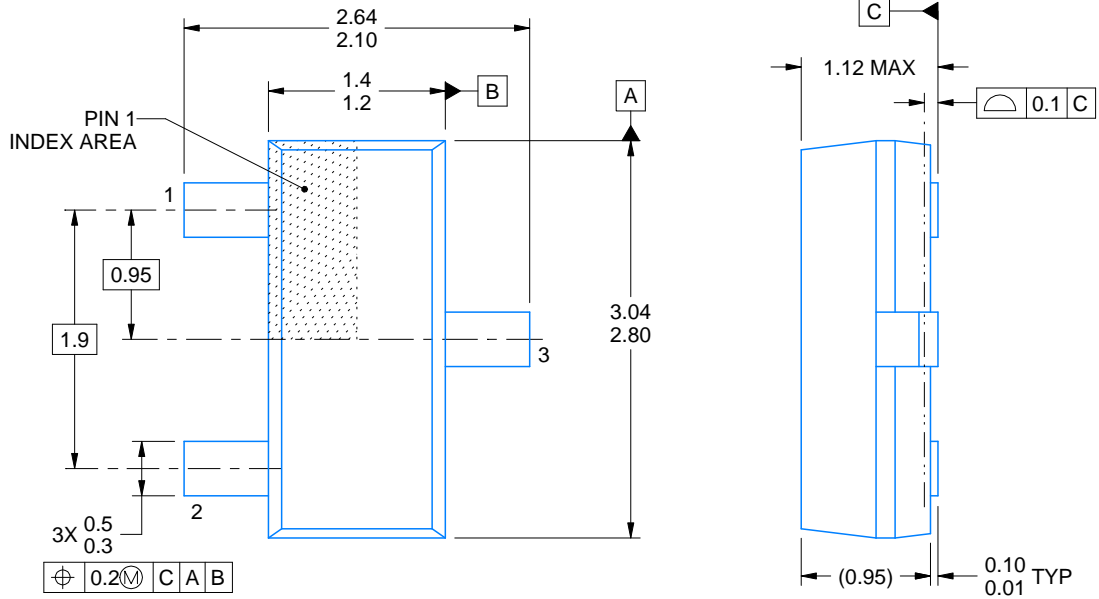

4214838/C 04/2017

NOTES:

1. All linear dimensions are in millimeters. Any dimensions in parenthesis are for reference only. Dimensioning and tolerancing per ASME Y14.5M.
2. This drawing is subject to change without notice.
3. Reference JEDEC registration TO-236, except minimum foot length.

# EXAMPLE BOARD LAYOUT

DBZ0003A

SOT-23 - 1.12 mm max height

SMALL OUTLINE TRANSISTOR



LAND PATTERN EXAMPLE  
SCALE:15X



SOLDER MASK DETAILS

4214838/C 04/2017

NOTES: (continued)

4. Publication IPC-7351 may have alternate designs.
5. Solder mask tolerances between and around signal pads can vary based on board fabrication site.

# EXAMPLE STENCIL DESIGN

DBZ0003A

SOT-23 - 1.12 mm max height

SMALL OUTLINE TRANSISTOR



SOLDER PASTE EXAMPLE  
BASED ON 0.125 THICK STENCIL  
SCALE:15X

4214838/C 04/2017

NOTES: (continued)

6. Laser cutting apertures with trapezoidal walls and rounded corners may offer better paste release. IPC-7525 may have alternate design recommendations.
7. Board assembly site may have different recommendations for stencil design.

## 重要声明和免责声明

TI 均以“原样”提供技术性及其可靠性数据（包括数据表）、设计资源（包括参考设计）、应用或其他设计建议、网络工具、安全信息和其他资源，不保证其中不含任何瑕疵，且不做任何明示或暗示的担保，包括但不限于对适销性、适合某特定用途或不侵犯任何第三方知识产权的暗示担保。

所述资源可供专业开发人员应用TI 产品进行设计使用。您将对以下行为独自承担全部责任：(1) 针对您的应用选择合适的TI 产品；(2) 设计、验证并测试您的应用；(3) 确保您的应用满足相应标准以及任何其他安全、安保或其他要求。所述资源如有变更，恕不另行通知。TI 对您使用所述资源的授权仅限于开发资源所涉及TI 产品的相关应用。除此之外不得复制或展示所述资源，也不提供其它TI 或任何第三方的知识产权授权许可。如因使用所述资源而产生任何索赔、赔偿、成本、损失及债务等，TI 对此概不负责，并且您须赔偿由此对TI 及其代表造成的损害。

TI 所提供产品均受TI 的销售条款 (<http://www.ti.com.cn/zh-cn/legal/termsofsale.html>) 以及ti.com.cn 上或随附TI 产品提供的其他可适用条款的约束。TI 提供所述资源并不扩展或以其他方式更改TI 针对TI 产品所发布的可适用的担保范围或担保免责声明。

邮寄地址：上海市浦东新区世纪大道 1568 号中建大厦 32 楼，邮政编码：200122

Copyright © 2020 德州仪器半导体技术（上海）有限公司