

4.5V 至 18V 输入，6.5A 同步降压转换器

查询样品: [TPS54625](#)

特性

- **D-CAP2™** 模式支持快速瞬态响应
- 低输出纹波，支持陶瓷输出电容器
- 宽 $V_{\text{输入}}$ 输入电压范围: **4.5V 至 18V**
- 输出电压范围: **0.76V 至 5.5V**
- 高效率集成型 **FET** 针对更低占空比应用进行了优化 - **36mΩ** (高侧) 与 **28mΩ** (低侧)
- 关断时的高效率，损耗不足 **10μA**
- 初始带隙参考的高精度
- 可调软启动
- 预偏置软启动
- **650kHz** 开关频率 (f_{sw})
- 逐周期限流
- 电源正常输出

应用范围

- 低电压系统的广泛应用
 - 数字电视电源
 - 高清 **Blu-ray Disc™** 播放器
 - 网络家庭终端设备
 - 数字机顶盒 (**STB**)

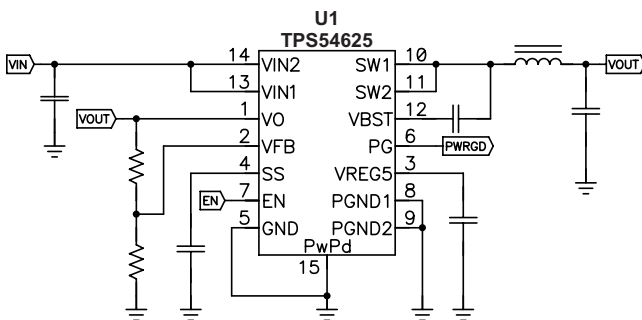

说明

TPS54625 是一款自适应接通时间 D-CAP2™ 模式同步降压转换器。TPS54625 可帮助系统设计人员用成本有效、低组件数量、低待机电流解决方案来完成不同终端设备的电源总线调节器集。

TPS54625 的主控制环路使用 D-CAP2™ 模式控制，此控制方式提供一个无需外部补偿组件的极快速瞬态响应。TPS54625 的专有电路还使该器件可采用诸如高分子有机半导体固体电容器 (POSCAP) 或高分子聚合物电容器 (SP-CAP) 等低等效串联电阻 (ESR) 输出电容器以及超低 ESR 陶瓷电容器。该器件的工作电压介于 4.5V 至 18V 的 V_{IN} 输入之间。输出电压可在 0.76V 与 5.5V 之间进行编程。该器件还特有一个可调软启动时间和一个电源正常功能。TPS54625 采用 14 引脚散热薄型小外形尺寸 (HTSSOP) 封装，设计工作温度介于 -40°C 到 85°C 之间。

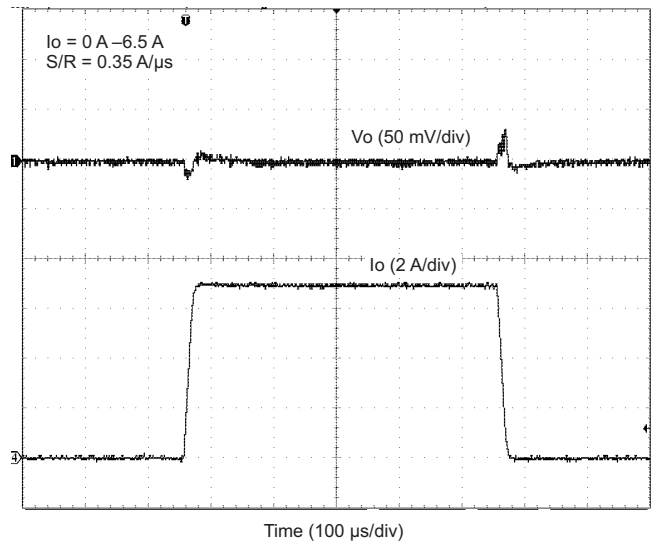

L004_SLVSC33



Please be aware that an important notice concerning availability, standard warranty, and use in critical applications of Texas Instruments semiconductor products and disclaimers thereto appears at the end of this data sheet.

D-CAP2, PowerPAD are trademarks of Texas Instruments.
Blu-ray Disc is a trademark of Blu-ray Disc Association.

PRODUCTION DATA information is current as of publication date. Products conform to specifications per the terms of the Texas Instruments standard warranty. Production processing does not necessarily include testing of all parameters.

Copyright © 2013, Texas Instruments Incorporated
English Data Sheet: [SLVSC33](#)



This integrated circuit can be damaged by ESD. Texas Instruments recommends that all integrated circuits be handled with appropriate precautions. Failure to observe proper handling and installation procedures can cause damage.

ESD damage can range from subtle performance degradation to complete device failure. Precision integrated circuits may be more susceptible to damage because very small parametric changes could cause the device not to meet its published specifications.

ORDERING INFORMATION⁽¹⁾

T _A	PACKAGE ⁽²⁾ ⁽³⁾	ORDERABLE PART NUMBER	PIN	TRANSPORT MEDIA, QUANTITY
–45°C to 85°C	PowerPAD™ (HTSSOP) – PWP	TPS54625PWP	14	Tube
		TPS54625PWPR		Tape and Reel

- (1) For the most current package and ordering information, see the Package Option Addendum at the end of this document, or see the TI web site at www.ti.com.
 (2) Package drawings, thermal data, and symbolization are available at www.ti.com/packaging.
 (3) All package options have Cu NIPDAU lead/ball finish.

ABSOLUTE MAXIMUM RATINGS

over operating free-air temperature range (unless otherwise noted) ⁽¹⁾

		VALUE	UNIT	
V _I	Input voltage range			
	VIN1, VIN2 EN	–0.3 to 20	V	
	VBST	–0.3 to 26	V	
	VBST (10 ns transient)	–0.3 to 28	V	
	VBST (vs SW1, SW2)	–0.3 to 6.5	V	
	VFB, VO, SS, PG	–0.3 to 6.5	V	
	SW1, SW2	–2 to 20	V	
	SW1, SW2 (10 ns transient)	–3 to 22	V	
V _O	Output voltage range			
	VREG5	–0.3 to 6.5	V	
	PGND1, PGND2	–0.3 to 0.3	V	
V _{diff}	Voltage from GND to POWERPAD	–0.2 to 0.2	V	
ESD rating	Electrostatic discharge	Human Body Model (HBM)	2	kV
		Charged Device Model (CDM)	500	V
T _J	Operating junction temperature	–40 to 150	°C	
T _{stg}	Storage temperature	–55 to 150	°C	

- (1) Stresses beyond those listed under *absolute maximum ratings* may cause permanent damage to the device. These are stress ratings only, and functional operation of the device at these or any other conditions beyond those indicated under *recommended operating conditions* is not implied. Exposure to absolute-maximum-rated conditions for extended periods may affect device reliability.

THERMAL INFORMATION

THERMAL METRIC ⁽¹⁾		TPS54625	UNITS
		PWP (14 PINS)	
θ _{JA}	Junction-to-ambient thermal resistance	40.5	°C/W
θ _{JCtop}	Junction-to-case (top) thermal resistance	28.7	
θ _{JB}	Junction-to-board thermal resistance	24.2	
ψ _{JT}	Junction-to-top characterization parameter	0.8	
ψ _{JB}	Junction-to-board characterization parameter	23.9	
θ _{JCbot}	Junction-to-case (bottom) thermal resistance	2.4	

- (1) For more information about traditional and new thermal metrics, see the IC Package Thermal Metrics application report, SPRA953.

RECOMMENDED OPERATING CONDITIONS

over operating free-air temperature range (unless otherwise noted)

		MIN	MAX	UNIT	
V_{IN}	Supply input voltage range	4.5	18	V	
V_I	Input voltage range	VBST	-0.1	24	V
		VBST(10 ns transient)	-0.1	27	
		VBST (vs SW)	-0.1	6.0	
		SS, PG	-0.1	5.7	
		EN	-0.1	18	
		VO, VFB	-0.1	5.5	
		SW1, SW2	-1.8	18	
		SW1, SW2 (10 ns transient)	-3	21	
	PGND1, PGND2	-0.1	0.1		
V_O	Output voltage range	VREG5	-0.1	5.7	V
I_O	Output Current range	I_{VREG5}	0	5	mA
R_{EN}	Power Good Resistor		25	150	k Ω
T_A	Operating free-air temperature		-40	85	$^{\circ}$ C
T_J	Operating junction temperature		-40	150	$^{\circ}$ C

ELECTRICAL CHARACTERISTICS

over operating free-air temperature range, $V_{IN} = 12V$ (unless otherwise noted)

PARAMETER		TEST CONDITIONS	MIN	TYP	MAX	UNIT
SUPPLY CURRENT						
I_{VIN}	Operating - non-switching supply current	V_{IN} current, $T_A = 25^{\circ}$ C, EN = 5 V, $V_{VFB} = 0.8$ V		950	1400	μ A
I_{VINSDN}	Shutdown supply current	V_{IN} current, $T_A = 25^{\circ}$ C, EN = 0 V		3.6	10	μ A
LOGIC THRESHOLD						
V_{ENH}	EN high-level input voltage	EN	1.6			V
V_{ENL}	EN low-level input voltage	EN			0.6	V
R_{EN}	EN pin resistance to GND	$V_{EN} = 12$ V	200	400	800	k Ω
VFB VOLTAGE AND DISCHARGE RESISTANCE						
V_{VFBTH}	VFB threshold voltage	$T_A = 25^{\circ}$ C, $V_O = 1.05$ V, continuous mode	757	765	773	mV
		$T_A = 0^{\circ}$ C to 85° C, $V_O = 1.05$ V, continuous mode ⁽¹⁾	753		777	
		$T_A = -40^{\circ}$ C to 85° C, $V_O = 1.05$ V, continuous mode ⁽¹⁾	751		779	
I_{VFB}	VFB input current	VFB = 0.8 V, $T_A = 25^{\circ}$ C		0	± 0.15	μ A
R_{Dischg}	V_O discharge resistance	$V_{EN} = 0$ V, $V_O = 0.5$ V, $T_A = 25^{\circ}$ C		100	150	Ω
VREG5 OUTPUT						
V_{VREG5}	VREG5 output voltage	$T_A = 25^{\circ}$ C, 6.0 V < V_{IN} < 18 V, $0 < I_{VREG5} < 5$ mA	5.2	5.5	5.7	V
I_{VREG5}	Output current	$V_{IN} = 6$ V, $V_{VREG5} = 4$ V, $T_A = 25^{\circ}$ C	20			mA
MOSFET						
R_{dsonh}	High side switch resistance	$T_A = 25^{\circ}$ C, $V_{BST} - V_{SW1,2} = 5.5$ V		36		m Ω
R_{dsonl}	Low side switch resistance	$T_A = 25^{\circ}$ C		28		m Ω

(1) Not production tested.

ELECTRICAL CHARACTERISTICS (continued)over operating free-air temperature range, $V_{IN} = 12V$ (unless otherwise noted)

PARAMETER		TEST CONDITIONS	MIN	TYP	MAX	UNIT
CURRENT LIMIT						
I_{OCL}	Current limit	$L_{OUT} = 1.5 \mu H^{(2)}$	7.2	8.2	9.5	A
THERMAL SHUTDOWN						
T_{SDN}	Thermal shutdown threshold	Shutdown temperature ⁽²⁾	165			°C
		Hysteresis ⁽²⁾	35			
ON-TIME TIMER CONTROL						
T_{ON}	On time	$V_{IN} = 12 V, V_O = 1.05 V$	150			ns
$T_{OFF(MIN)}$	Minimum off time	$T_A = 25^\circ C, V_{VFB} = 0.7 V$	260	310	ns	
SOFT START						
I_{SSC}	SS charge current	$V_{SS} = 1 V$	4.2	6.0	7.8	μA
I_{SSD}	SS discharge current	$V_{SS} = 0.5 V$	1.5	3.3	mA	
POWER GOOD						
V_{THPG}	PG threshold	V_{VFB} rising (good)	85%	90%	95%	
		V_{VFB} falling (fault)	85%			
I_{PG}	PG sink current	$V_{PG} = 0.5 V$	2.5	5	mA	
OUTPUT UNDERVOLTAGE AND OVERVOLTAGE PROTECTION						
V_{OVP}	Output OVP trip threshold	OVP detect	120%	125%	130%	
T_{OVPDEL}	Output OVP prop delay		10			μs
V_{UVP}	Output UVP trip threshold	UVP detect	60%	65%	70%	
		Hysteresis	10%			
T_{UVPDEL}	Output UVP delay		0.25			ms
T_{UVPEN}	Output UVP enable delay	Relative to soft-start time	X 1.7			
UVLO						
V_{UVLO}	UVLO threshold	Wake up VREG5 voltage	3.45	3.75	4.05	V
		Hysteresis VREG5 voltage	0.13	0.32	0.48	

(2) Not production tested.

DEVICE INFORMATION

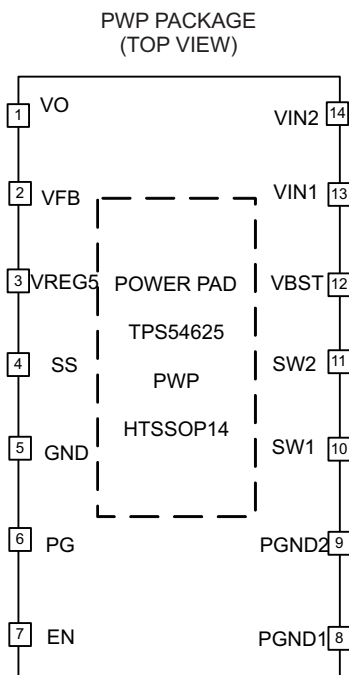

PIN FUNCTIONS

PIN		DESCRIPTION
NAME	NUMBER	
VO	1	Connect to output of converter. This pin is used for output discharge function.
VFB	2	Converter feedback input. Connect with feedback resistor divider.
VREG5	3	5.5V power supply output. An external capacitor (typical 1uF) should be connected to GND. VREG5 is not active when EN is low.
SS	4	Soft start control. An external capacitor should be connected to GND.
GND	5	Signal ground pin.
PG	6	Open drain power good output
EN	7	Enable control input. EN is active high and must be pulled up to enable the device.
PGND1, PGND2	8, 9	Ground returns for low-side MOSFET. Also serve as inputs of current comparators. Connect PGND and GND strongly together near the IC.
SW1, SW2	10, 11	Switch node connection between high-side NFET and low-side NFET. Also serve as inputs to current comparator.
VBST	12	Supply input for high-side NFET gate driver (boost terminal). Connect capacitor from this pin to respective SW1, SW2 terminals. An internal PN diode is connected between VREG5 and VBST pin.
VIN1, VIN2	13, 14	Power Input and connected to high side NFET drain. Supply Input for 5V internal linear regulator for the control circuitry
PowerPAD™	Back side	Thermal pad of the package. Must be soldered to achieve appropriate dissipation. Should be connected to PGND

FUNCTIONAL BLOCK DIAGRAM (HTSSOP)

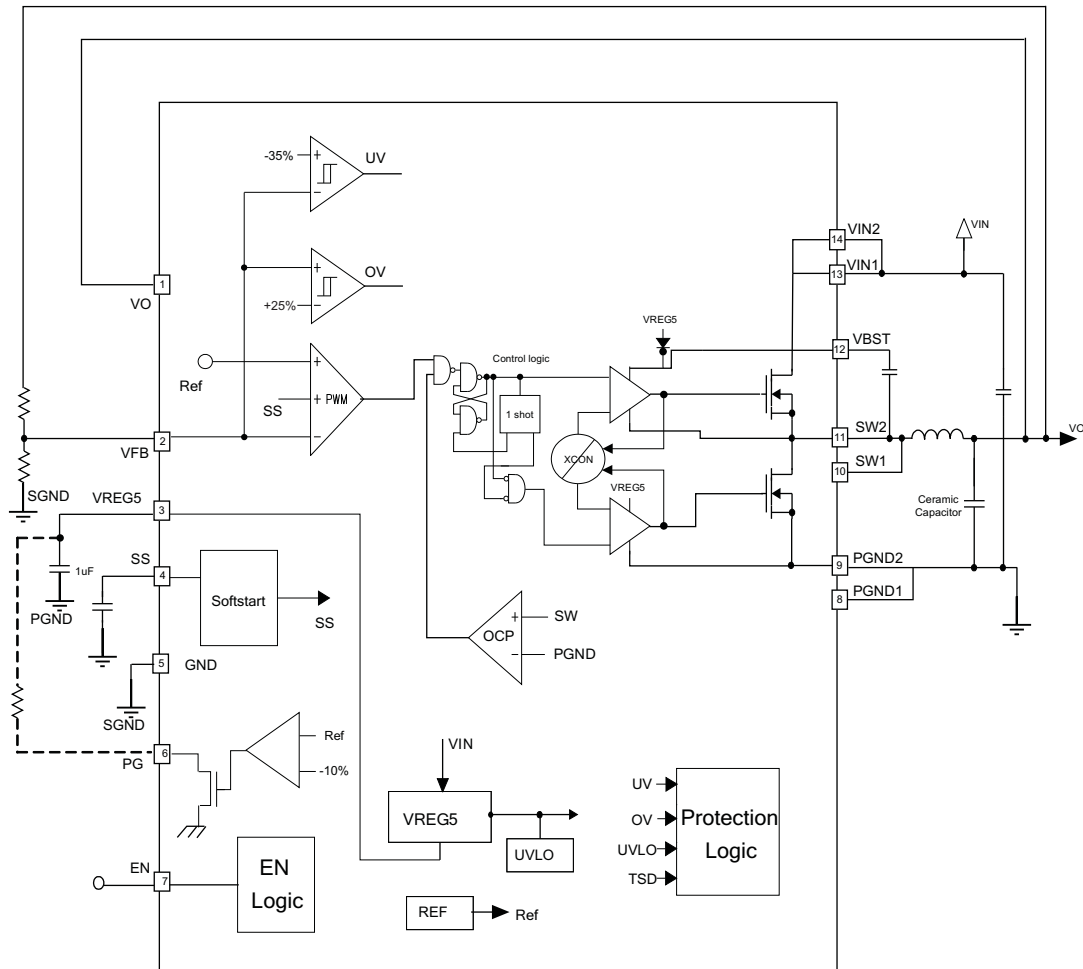

OVERVIEW

The TPS54625 is a 6.5A synchronous step-down (buck) converter with two integrated N-channel MOSFETs with Auto-Skip mode to improve light load efficiency. It operates using D-CAP2™ mode control. The fast transient response of D-CAP2™ control reduces the output capacitance required to meet a specific level of performance. Proprietary internal circuitry allows the use of low ESR output capacitors including ceramic and special polymer types.

DETAILED DESCRIPTION

PWM Operation

The main control loop of the TPS54625 is an adaptive on-time pulse width modulation (PWM) controller that supports a proprietary D-CAP2™ mode control. D-CAP2™ mode control combines constant on-time control with an internal compensation circuit for pseudo-fixed frequency and low external component count configuration with both low ESR and ceramic output capacitors. It is stable even with virtually no ripple at the output.

At the beginning of each cycle, the high-side MOSFET is turned on. This MOSFET is turned off after internal one shot timer expires. This one shot is set by the converter input voltage, VIN, and the output voltage, VO, to maintain a pseudo-fixed frequency over the input voltage range, hence it is called adaptive on-time control. The one-shot timer is reset and the high-side MOSFET is turned on again when the feedback voltage falls below the reference voltage. An internal ramp is added to reference voltage to simulate output ripple, eliminating the need for ESR induced output ripple from D-CAP2™ mode control.

PWM Frequency and Adaptive On-Time Control

TPS54625 uses an adaptive on-time control scheme and does not have a dedicated on board oscillator. The TPS54625 runs with a pseudo-constant frequency of 650 kHz by using the input voltage and output voltage to set the on-time one-shot timer. The on-time is inversely proportional to the input voltage and proportional to the output voltage. The actual frequency may vary from 650kHz depending on the off time, which is ended when the feed back portion of the output voltage falls to the V_{FB} threshold voltage.

Soft Start and Pre-Biased Soft Start

The soft start function is adjustable. When the EN pin becomes high, 6-μA current begins charging the capacitor which is connected from the SS pin to GND. Smooth control of the output voltage is maintained during start up. The equation for the slow start time is shown in [Equation 1](#). VFB voltage is 0.765 V and SS pin source current is 6 μA.

$$t_{SS}(\text{ms}) = \frac{C_{SS}(\text{nF}) \times V_{REF} \times 1.1}{I_{SS}(\mu\text{A})} = \frac{C_{SS}(\text{nF}) \times 0.765 \times 1.1}{6} \quad (1)$$

TPS54625 contains a unique circuit to prevent current from being pulled from the output during startup if the output is pre-biased. When the soft-start commands a voltage higher than the pre-bias level (internal soft-start becomes greater than feedback voltage V_{FB}), the controller slowly activates synchronous rectification by starting the first low side FET gate driver pulses with a narrow on-time. It then increments that on-time on a cycle-by-cycle basis until it coincides with the time dictated by (1-D), where D is the duty cycle of the converter. This scheme prevents the initial sinking of the pre-bias output, and ensure that the out voltage (VO) starts and ramps up smoothly into regulation and the control loop is given time to transition from pre-biased start-up to normal mode operation .

Power Good

TPS54625 has power-good open drain output. The power-good function is activated after soft start has finished. The power good function becomes active after 1.7 times soft-start time. When the output voltage becomes within –10% of the target value, internal comparators detect power good state and the power good signal becomes high. Rpg resistor value, which is connected between PG and VREG5, is required from 25 kΩ to 150 kΩ. If the feedback voltage goes under 15% of the target value, the power good signal becomes low.

Output Discharge Control

TPS54625 discharges the output when EN is low, or the controller is turned off by the protection functions (UVP, UVLO and thermal shutdown). The device discharges the output using an internal 100-Ω MOSFET which is connected to VO and GND. The internal low-side MOSFET is not turned on for the output discharge operation to avoid the possibility of causing negative voltage at the output.

Current Protection

The output over-current protection(OCP) is implemented using a cycle-by-cycle valley detect control circuit. The switch current is monitored by measuring the low-side FET switch voltage between the SW and GND. This voltage is proportional to the switch current. To improve accuracy, the voltage sensing is temperature compensated.

During the on time of the high-side FET switch, the switch current increases at a linear rate determined by V_{in} , V_{out} , the on-time and the output inductor value. During the on time of the low-side FET switch, this current decreases linearly. The average value of the switch current is the load current I_{out} . The TPS54625 constantly monitors the low-side FET switch voltage, which is proportional to the switch current, during the low-side on-time. If the measured voltage is above the voltage proportional to the current limit, an internal counter is incremented per each SW cycle and the converter maintains the low-side switch on until the measured voltage is below the voltage corresponding to the current limit at which time the switching cycle is terminated and a new switching cycle begins. In subsequent switching cycles, the on-time is set to a fixed value and the current is monitored in the same manner.

There are some important considerations for this type of over-current protection. The load current one half of the peak-to-peak inductor current is higher than the over-current threshold. Also, when the current is being limited, the output voltage tends to fall as the demanded load current may be higher than the current available from the converter. This may cause the output voltage to fall.

Over/Under Voltage Protection

TPS54625 detects over and under voltage conditions by monitoring the feedback voltage (VFB). This function is enabled after approximately 1.7 x times the softstart time.

When the feedback voltage becomes higher than 125% of the target voltage, the OVP comparator output goes high and the circuit latches and both the high-side MOSFET driver and the low-side MOSFET driver turn off.

When the feedback voltage becomes lower than 65% of the target voltage, the UVP comparator output goes high and an internal UVP delay counter begins. After 250us, the device latches off both internal top and bottom MOSFET.

UVLO Protection

Under voltage lock out protection (UVLO) monitors the voltage of $V_{REG5, pin}$. When the VREG5 voltage is lower than UVLO threshold voltage, The TPS54625 is shut off. This protection is non-latching.

Thermal Shutdown

Thermal protection is self-activating. If the junction temperature exceeds the threshold value (typically 165°C), the TPS54625 is shut off. This is non-latch protection.

TYPICAL CHARACTERISTICS

$V_{IN} = 12\text{ V}$, $T_A = 25\text{ }^\circ\text{C}$ (unless otherwise noted)

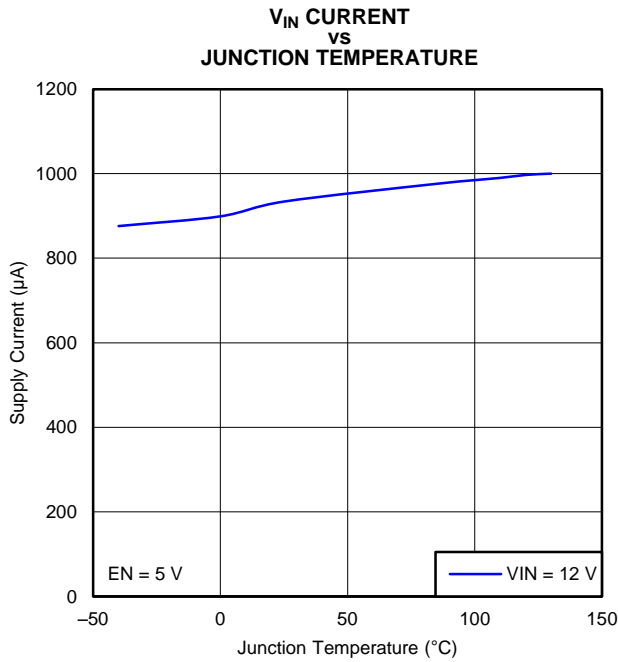

Figure 1.

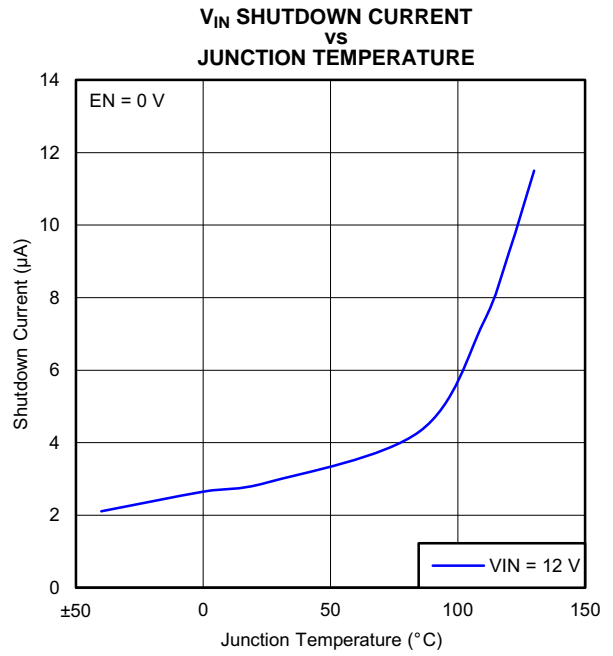

Figure 2.

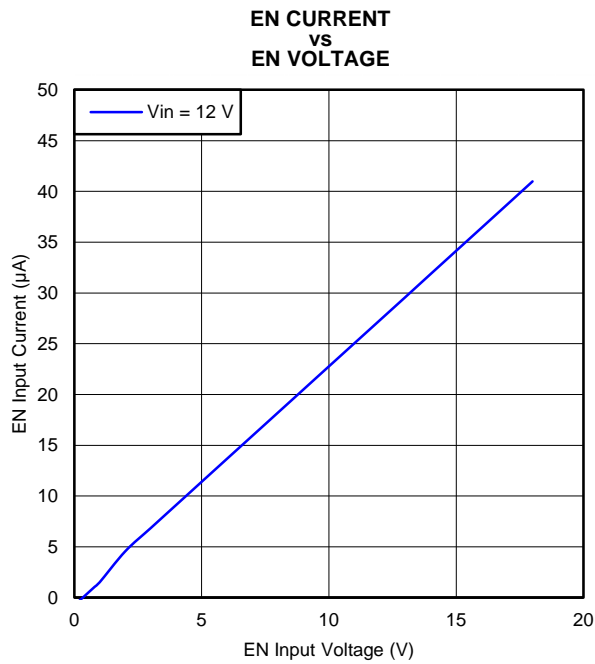

Figure 3.

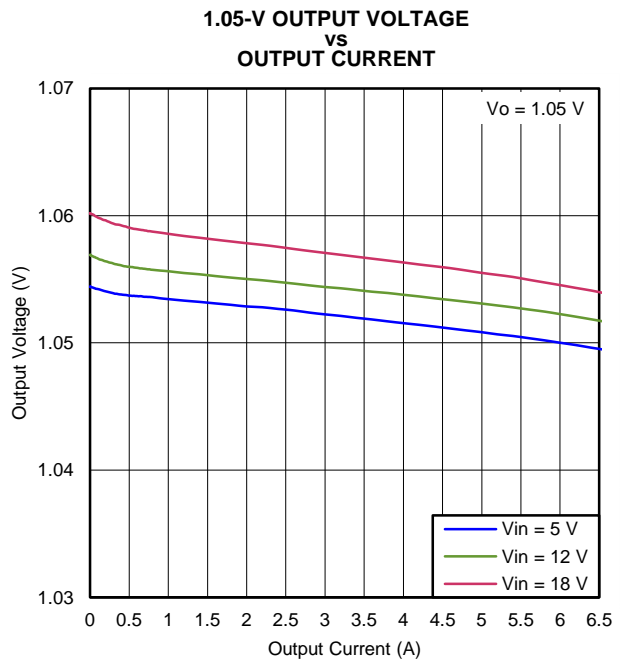

Figure 4.

TYPICAL CHARACTERISTICS (continued)

$V_{IN} = 12\text{ V}$, $T_A = 25\text{ }^\circ\text{C}$ (unless otherwise noted)

1.05-V OUTPUT VOLTAGE
vs
INPUT VOLTAGE

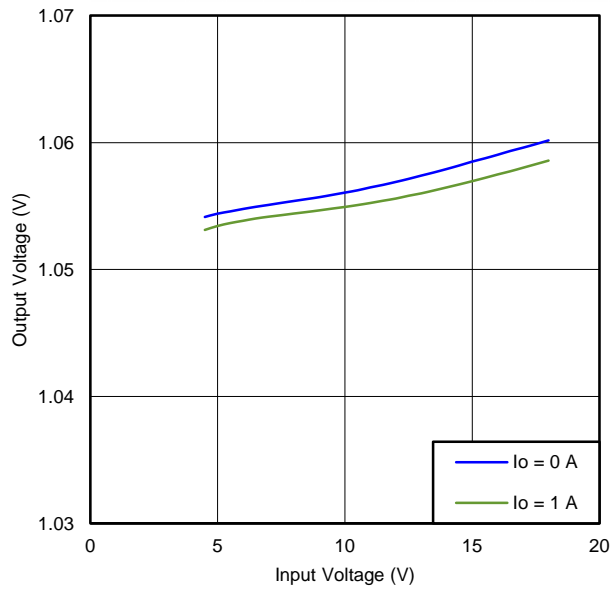

Figure 5.

1.05-V, 0-mA to 6.5-A LOAD TRANSIENT RESPONSE

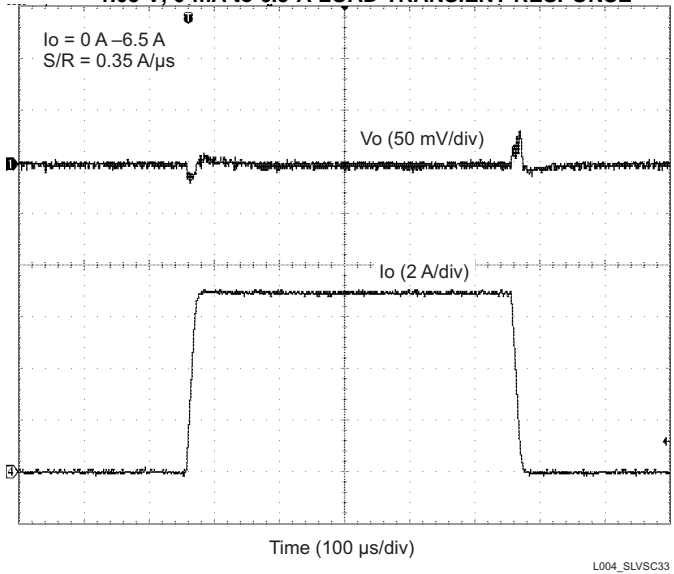

Figure 6.

START-UP WAVE FORM

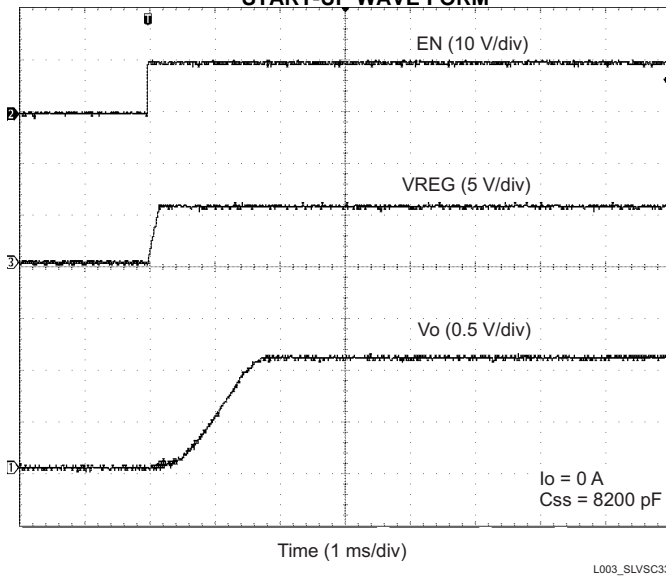

Figure 7.

EFFICIENCY vs OUTPUT CURRENT (12 V)

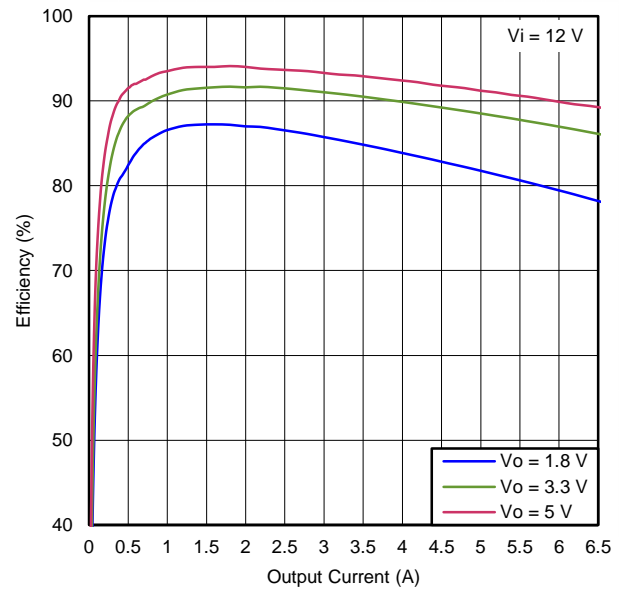

Figure 8.

TYPICAL CHARACTERISTICS (continued)

$V_{IN} = 12\text{ V}$, $T_A = 25\text{ }^\circ\text{C}$ (unless otherwise noted)

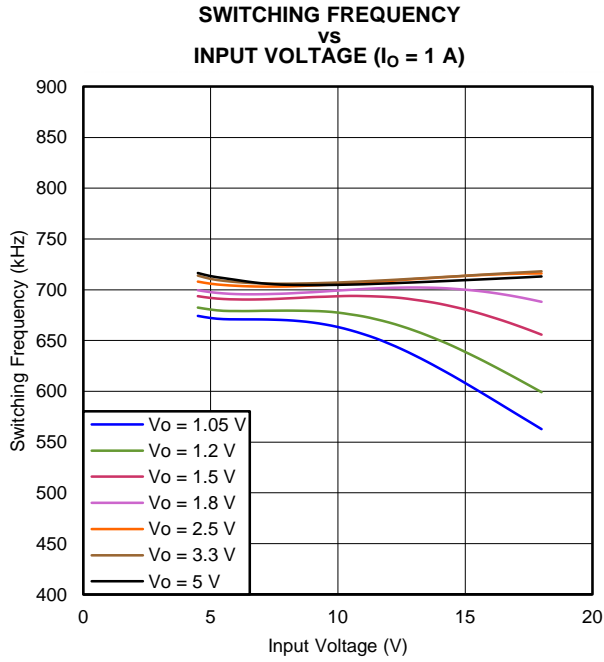

Figure 9.

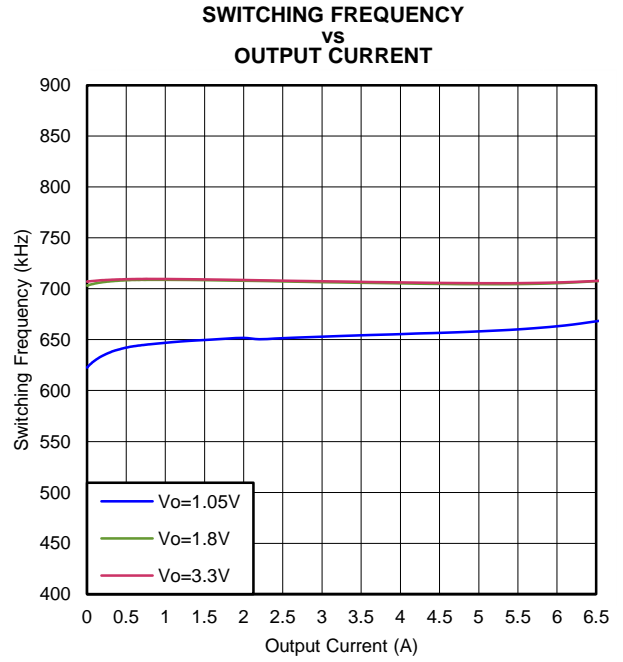

Figure 10.

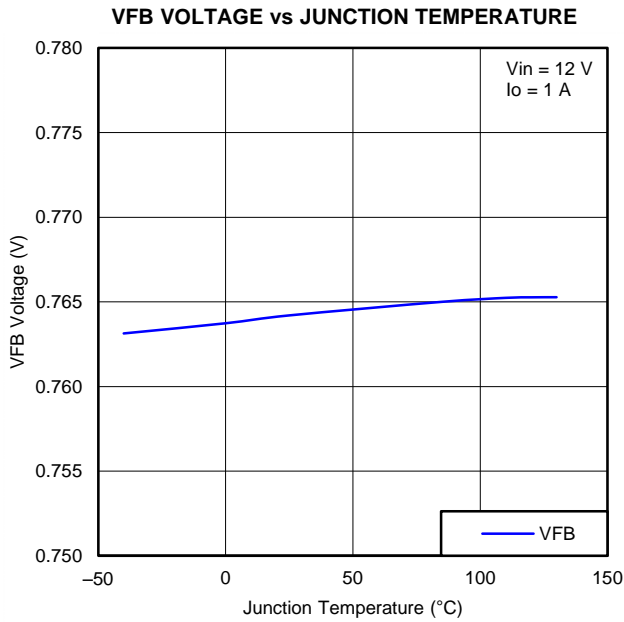

Figure 11.

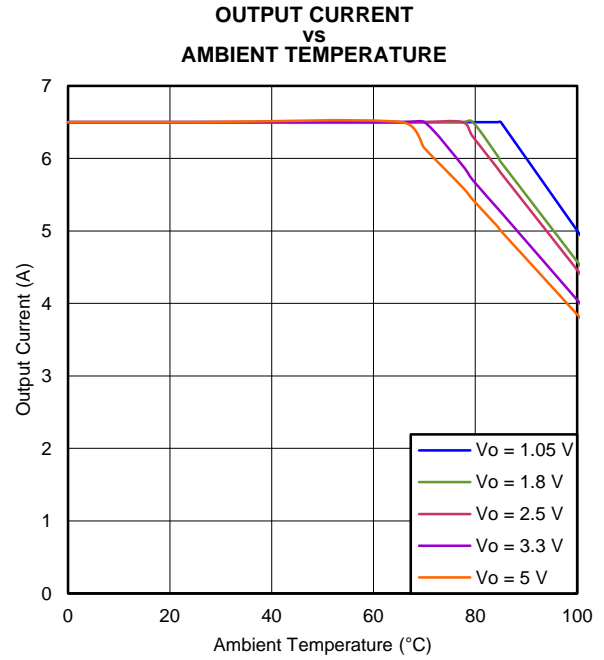

Figure 12.

TYPICAL CHARACTERISTICS (continued)

$V_{IN} = 12\text{ V}$, $T_A = 25\text{ }^\circ\text{C}$ (unless otherwise noted)

VOLTAGE RIPPLE AT INPUT ($I_O = 6.5\text{ A}$)

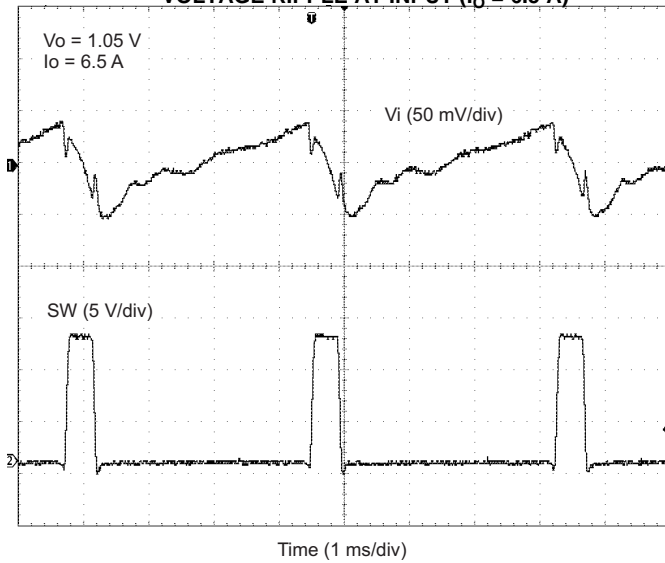

Figure 13.

VOLTAGE RIPPLE AT OUTPUT ($I_O = 6.5\text{ A}$)

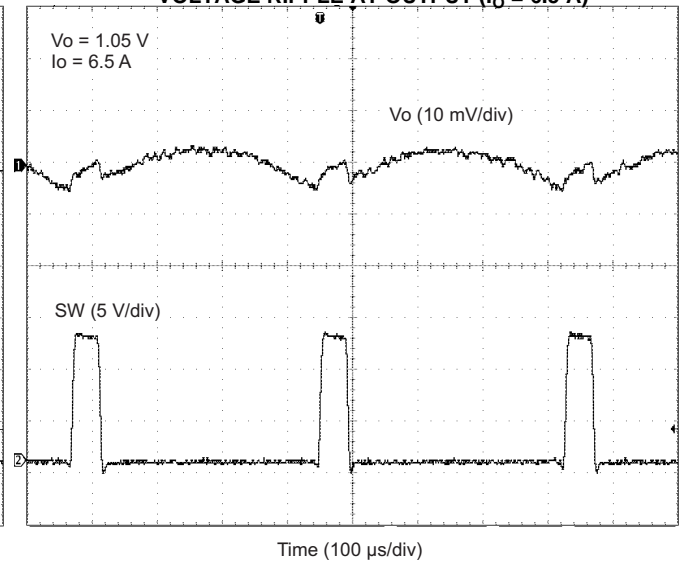

Figure 14.

DESIGN GUIDE

Step By Step Design Procedure

To begin the design process, you must know a few application parameters:

- Input voltage range
- Output voltage
- Output current
- Output voltage ripple
- Input voltage ripple

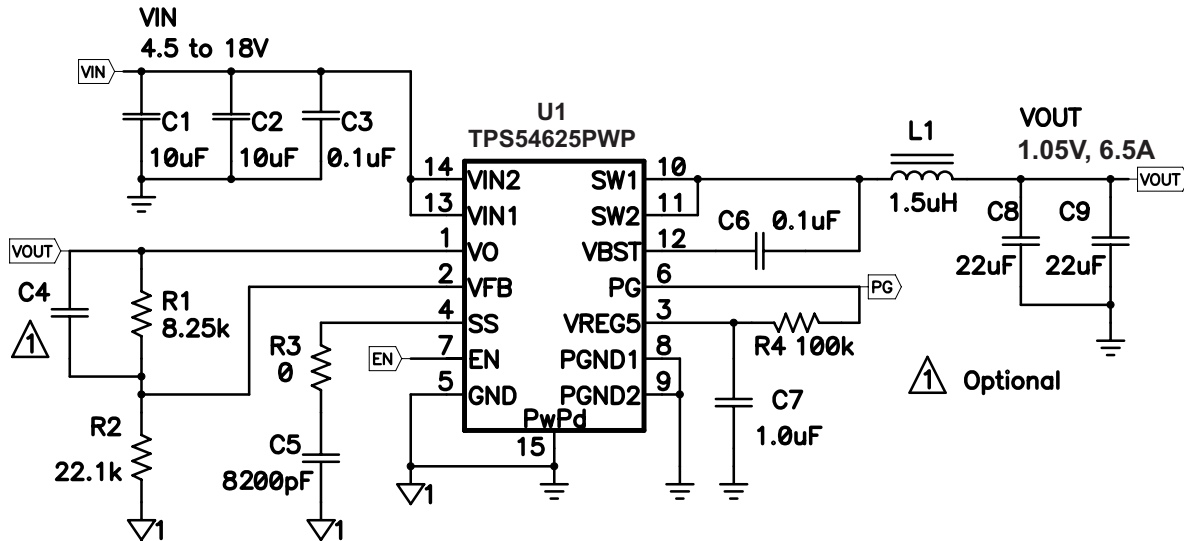

Figure 15. Schematic

Output Voltage Resistors Selection

The output voltage is set with a resistor divider from the output node to the VFB pin. It is recommended to use 1% tolerance or better divider resistors. Start by using Equation 2 to calculate V_{OUT} .

To improve efficiency at very light loads consider using larger value resistors, too high of resistance will be more susceptible to noise and voltage errors from the VFB input current will be more noticeable.

$$V_{OUT} = 0.765 \cdot \left(1 + \frac{R1}{R2}\right) \quad (2)$$

Output Filter Selection

The output filter used with the TPS54625 is an LC circuit. This LC filter has double pole at:

$$F_P = \frac{1}{2\pi \sqrt{L_{OUT} \times C_{OUT}}} \quad (3)$$

At low frequencies, the overall loop gain is set by the output set-point resistor divider network and the internal gain of the TPS54625. The low frequency phase is 180 degrees. At the output filter pole frequency, the gain rolls off at a -40 dB per decade rate and the phase drops rapidly. D-CAP2™ introduces a high frequency zero that reduces the gain roll off to -20 dB per decade and increases the phase to 90 degrees one decade above the zero frequency. The inductor and capacitor selected for the output filter must be selected so that the double pole of Equation 3 is located below the high frequency zero but close enough that the phase boost provided by the high frequency zero provides adequate phase margin for a stable circuit. To meet this requirement use the values recommended in Table 1

Table 1. Recommended Component Values

Output Voltage (V)	R1 (kΩ)	R2 (kΩ)	C4 (pF)	L1 (μH)	C8 + C9 (μF)
1	6.81	22.1	5 - 220	1.0 - 1.5 - 4.7	22 - 68
1.05	8.25	22.1	5 - 220	1.0 - 1.5 - 4.7	22 - 68
1.2	12.7	22.1	5 - 100	1.0 - 1.5 - 4.7	22 - 68
1.5	21.5	22.1	5 - 68	1.0 - 1.5 - 4.7	22 - 68
1.8	30.1	22.1	5 - 22	1.2 - 1.5 - 4.7	22 - 68
2.5	49.9	22.1	5 - 22	1.5 - 2.2 - 4.7	22 - 68
3.3	73.2	22.1	5 - 22	1.8 - 2.2 - 4.7	22 - 68
5	124	22.1	5 - 22	2.5 - 3.3 - 4.7	22 - 68

For higher output voltages at or above 1.8 V, additional phase boost can be achieved by adding a feed forward capacitor (C4) in parallel with R1.

Since the DC gain is dependent on the output voltage, the required inductor value will increase as the output voltage increases. For higher output voltages at or above 1.8 V, additional phase boost can be achieved by adding a feed forward capacitor (C4) in parallel with R1

The inductor peak-to-peak ripple current, peak current and RMS current are calculated using [Equation 4](#), [Equation 5](#) and [Equation 6](#). The inductor saturation current rating must be greater than the calculated peak current and the RMS or heating current rating must be greater than the calculated RMS current. Use 650 kHz for f_{SW} .

Use 650 kHz for f_{SW} and also use 1.5μH for L_o . Make sure the chosen inductor is rated for the peak current of [Equation 5](#) and the RMS current of [Equation 6](#).

$$I_{pp} - p = \frac{V_{OUT}}{V_{IN(max)}} \cdot \frac{V_{IN(max)} - V_{OUT}}{L_o \cdot f_{SW}} \quad (4)$$

$$I_{lpeak} = I_o + \frac{I_{pp} - p}{2} \quad (5)$$

$$I_{Lo(RMS)} = \sqrt{I_o^2 + \frac{1}{12} I_{pp} - p^2} \quad (6)$$

For this design example, the calculated peak current is 7.01 A and the calculated RMS current is 6.51 A. The inductor used is a TDK SPM6530-1R5M100 with a peak current rating of 11.5 A and an RMS current rating of 11 A.

The capacitor value and ESR determines the amount of output voltage ripple. The TPS54625 is intended for use with ceramic or other low ESR capacitors. Recommended values range from 22μF to 68μF. Use [Equation 7](#) to determine the required RMS current rating for the output capacitor.

$$I_{CO(RMS)} = \frac{V_{OUT} \cdot (V_{IN} - V_{OUT})}{\sqrt{12} \cdot V_{IN} \cdot L_o \cdot f_{SW}} \quad (7)$$

For this design two TDK C3216X5R0J226M 22μF output capacitors are used. The typical ESR is 2 mΩ each. The calculated RMS current is 0.286 A and each output capacitor is rated for 4A.

Input Capacitor Selection

The TPS54625 requires an input decoupling capacitor and a bulk capacitor is needed depending on the application. A ceramic capacitor over 10 μF is recommended for the decoupling capacitor. An additional 0.1 μF capacitor from pin 14 to ground is recommended to improve the EMI performance. The capacitor voltage rating needs to be greater than the maximum input voltage.

Bootstrap Capacitor Selection

A 0.1 μF ceramic capacitor must be connected between the VBST to SW pin for proper operation. It is recommended to use a ceramic capacitor.

VREG5 Capacitor Selection

A 1.0 μF ceramic capacitor must be connected between the VREG5 to GND pin for proper operation. It is recommended to use a ceramic capacitor.

THERMAL INFORMATION

This PowerPad™ package incorporates an exposed thermal pad that is designed to be directly to an external heatsink. The thermal pad must be soldered directly to the printed board (PCB). After soldering, the PCB can be used as a heatsink. In addition, through the use of thermal vias, the thermal pad can be attached directly to the appropriate copper plane shown in the electrical schematic for the device, or alternatively, can be attached to a special heatsink structure designed into the PCB. This design optimizes the heat transfer from the integrated circuit (IC).

For additional information on the PowerPAD™ package and how to use the advantage of its heat dissipating abilities, refer to Technical Brief, *PowerPAD™ Thermally Enhanced Package*, Texas Instruments Literature No. [SLMA002](#) and Application Brief, *PowerPAD™ Made Easy*, Texas Instruments Literature No. [SLMA004](#).

The exposed thermal pad dimensions for this package are shown in the following illustration.

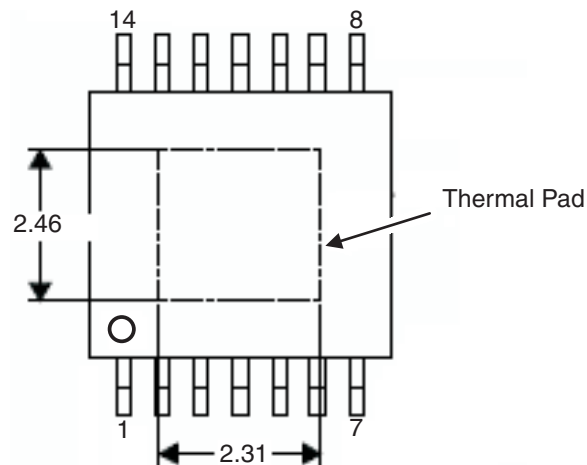

Figure 16. Thermal Pad Dimensions

LAYOUT CONSIDERATIONS

1. A top side area should be filled with ground as much as possible due to relatively higher current output device.
2. The ground area under the device thermal pad should be large as possible and directly connect to the thermal pad. Also 2nd, 3rd and 4th PCB layer should be connected to ground directly from the thermal pad.
3. Keep the input switching current loop as small as possible.
4. Keep the SW node as physically small and short as possible to minimize parasitic capacitance and inductance and to minimize radiated emissions. Kelvin connections should be brought from the output to the feedback pin of the device.
5. Keep analog and non-switching components away from switching components.
6. Make a single point connection from the signal ground to power ground.
7. Do not allow switching current to flow under the device.
8. Keep the pattern lines for VIN and PGND broad.
9. Exposed pad of device must be connected to PGND with solder.
10. VREG5 capacitor should be placed near the device, and connected PGND.
11. Output capacitor should be connected to a broad pattern of the PGND.
12. Voltage feedback loop should be as short as possible, and preferably with ground shield.
13. Lower resistor of the voltage divider which is connected to the VFB pin should be tied to SGND.
14. Providing sufficient via is preferable for VIN, SW and PGND connection.
15. PCB pattern for VIN, SW, and PGND should be as broad as possible.
16. VIN Capacitor should be placed as near as possible to the device.

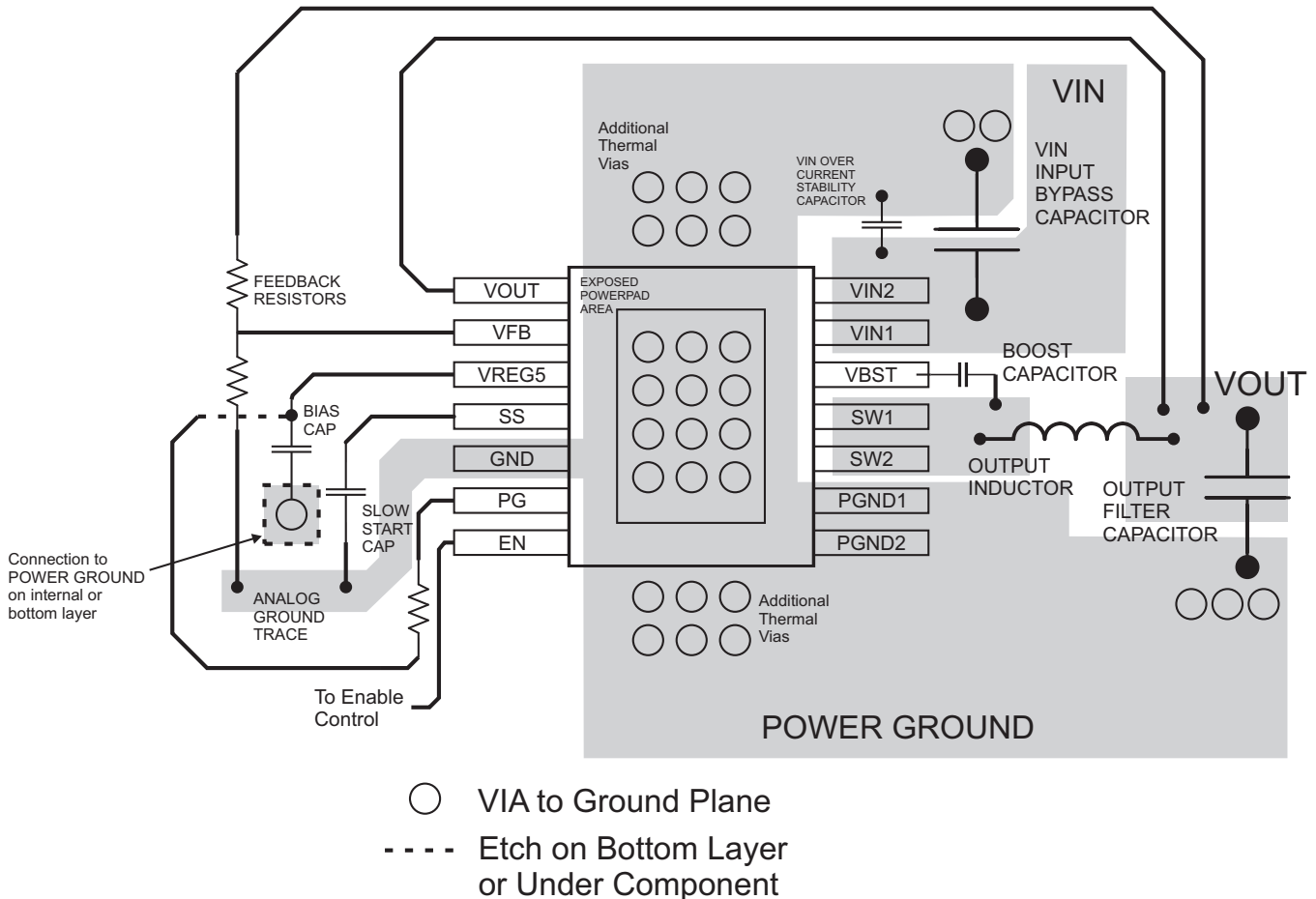

Figure 17. PCB Layout

PACKAGING INFORMATION

Orderable Device	Status (1)	Package Type	Package Drawing	Pins	Package Qty	Eco Plan (2)	Lead finish/ Ball material (6)	MSL Peak Temp (3)	Op Temp (°C)	Device Marking (4/5)	Samples
TPS54625PWP	ACTIVE	HTSSOP	PWP	14	90	RoHS & Green	NIPDAU	Level-2-260C-1 YEAR	-40 to 85	PS54625	Samples
TPS54625PWPR	ACTIVE	HTSSOP	PWP	14	2000	RoHS & Green	NIPDAU	Level-2-260C-1 YEAR	-40 to 85	PS54625	Samples

(1) The marketing status values are defined as follows:

ACTIVE: Product device recommended for new designs.

LIFEBUY: TI has announced that the device will be discontinued, and a lifetime-buy period is in effect.

NRND: Not recommended for new designs. Device is in production to support existing customers, but TI does not recommend using this part in a new design.

PREVIEW: Device has been announced but is not in production. Samples may or may not be available.

OBSOLETE: TI has discontinued the production of the device.

(2) **RoHS:** TI defines "RoHS" to mean semiconductor products that are compliant with the current EU RoHS requirements for all 10 RoHS substances, including the requirement that RoHS substance do not exceed 0.1% by weight in homogeneous materials. Where designed to be soldered at high temperatures, "RoHS" products are suitable for use in specified lead-free processes. TI may reference these types of products as "Pb-Free".

RoHS Exempt: TI defines "RoHS Exempt" to mean products that contain lead but are compliant with EU RoHS pursuant to a specific EU RoHS exemption.

Green: TI defines "Green" to mean the content of Chlorine (Cl) and Bromine (Br) based flame retardants meet JS709B low halogen requirements of <=1000ppm threshold. Antimony trioxide based flame retardants must also meet the <=1000ppm threshold requirement.

(3) MSL, Peak Temp. - The Moisture Sensitivity Level rating according to the JEDEC industry standard classifications, and peak solder temperature.

(4) There may be additional marking, which relates to the logo, the lot trace code information, or the environmental category on the device.

(5) Multiple Device Markings will be inside parentheses. Only one Device Marking contained in parentheses and separated by a "~" will appear on a device. If a line is indented then it is a continuation of the previous line and the two combined represent the entire Device Marking for that device.

(6) Lead finish/Ball material - Orderable Devices may have multiple material finish options. Finish options are separated by a vertical ruled line. Lead finish/Ball material values may wrap to two lines if the finish value exceeds the maximum column width.

Important Information and Disclaimer:The information provided on this page represents TI's knowledge and belief as of the date that it is provided. TI bases its knowledge and belief on information provided by third parties, and makes no representation or warranty as to the accuracy of such information. Efforts are underway to better integrate information from third parties. TI has taken and continues to take reasonable steps to provide representative and accurate information but may not have conducted destructive testing or chemical analysis on incoming materials and chemicals. TI and TI suppliers consider certain information to be proprietary, and thus CAS numbers and other limited information may not be available for release.

In no event shall TI's liability arising out of such information exceed the total purchase price of the TI part(s) at issue in this document sold by TI to Customer on an annual basis.

GENERIC PACKAGE VIEW

PWP 14

PowerPAD TSSOP - 1.2 mm max height

4.4 x 5.0, 0.65 mm pitch

PLASTIC SMALL OUTLINE

This image is a representation of the package family, actual package may vary.
Refer to the product data sheet for package details.

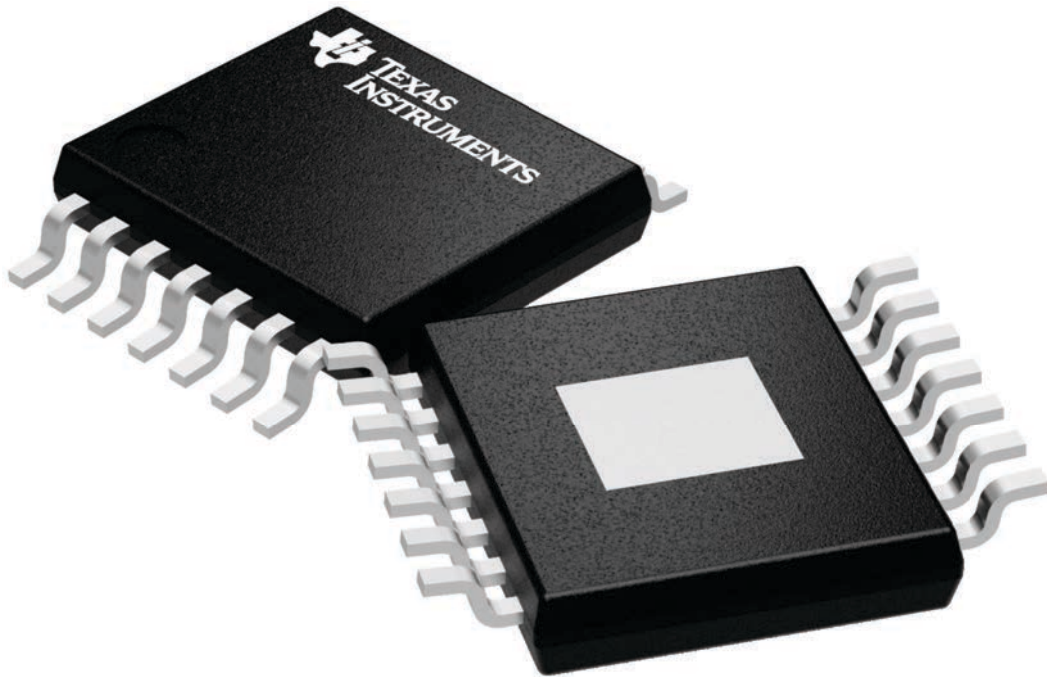

4224995/A

PWP (R-PDSO-G14)

PowerPAD™ PLASTIC SMALL OUTLINE

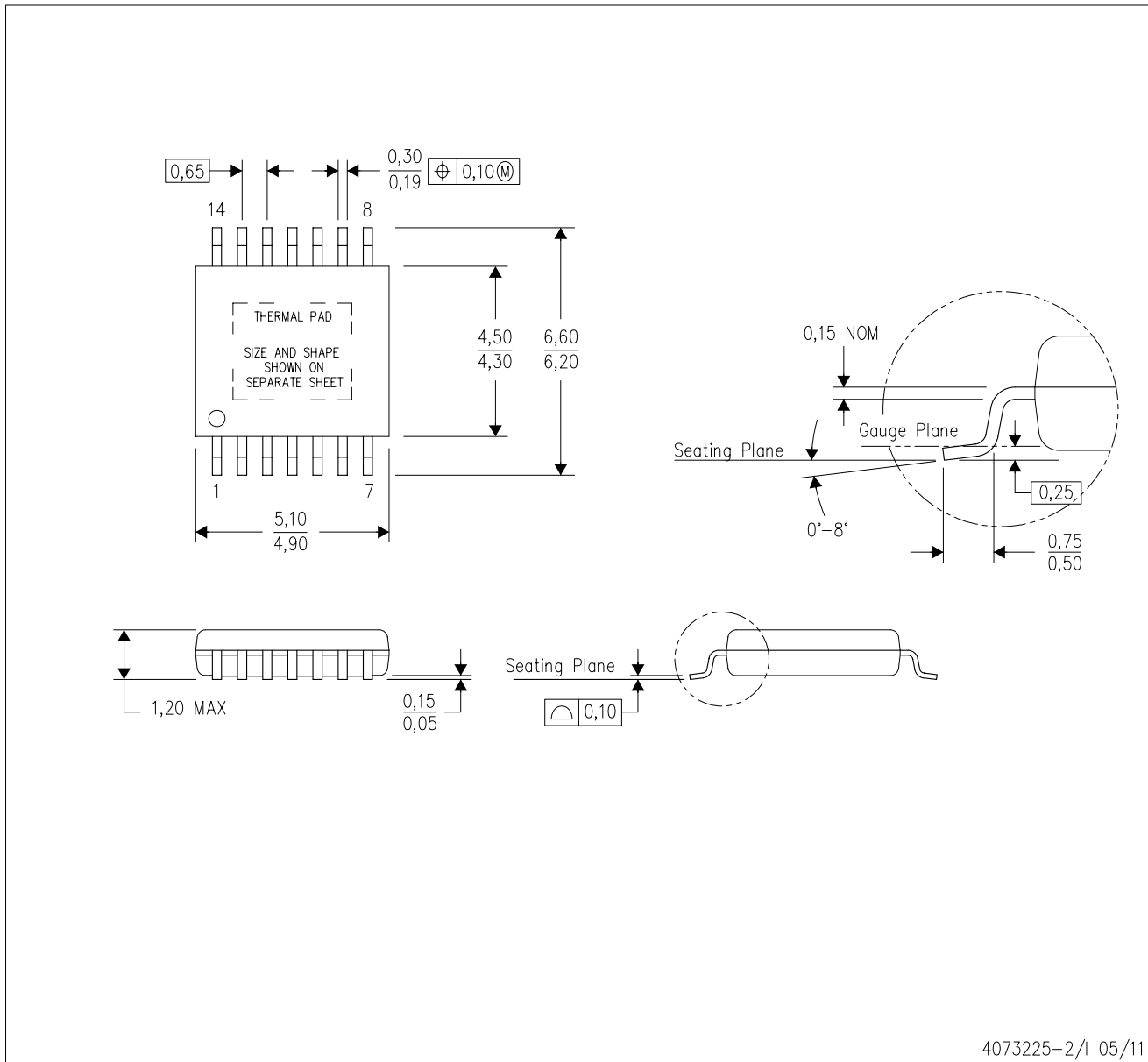

4073225-2/1 05/11

- NOTES:
- All linear dimensions are in millimeters.
 - This drawing is subject to change without notice.
 - Body dimensions do not include mold flash or protrusions. Mold flash and protrusion shall not exceed 0.15 per side.
 - This package is designed to be soldered to a thermal pad on the board. Refer to Technical Brief, PowerPad Thermally Enhanced Package, Texas Instruments Literature No. SLMA002 for information regarding recommended board layout. This document is available at www.ti.com <<http://www.ti.com>>.
 - See the additional figure in the Product Data Sheet for details regarding the exposed thermal pad features and dimensions.
 - Falls within JEDEC MO-153

PowerPAD is a trademark of Texas Instruments.

THERMAL PAD MECHANICAL DATA

PWP (R-PDSO-G14)

PowerPAD™ SMALL PLASTIC OUTLINE

THERMAL INFORMATION

This PowerPAD™ package incorporates an exposed thermal pad that is designed to be attached to a printed circuit board (PCB). The thermal pad must be soldered directly to the PCB. After soldering, the PCB can be used as a heatsink. In addition, through the use of thermal vias, the thermal pad can be attached directly to the appropriate copper plane shown in the electrical schematic for the device, or alternatively, can be attached to a special heatsink structure designed into the PCB. This design optimizes the heat transfer from the integrated circuit (IC).

For additional information on the PowerPAD package and how to take advantage of its heat dissipating abilities, refer to Technical Brief, PowerPAD Thermally Enhanced Package, Texas Instruments Literature No. SLMA002 and Application Brief, PowerPAD Made Easy, Texas Instruments Literature No. SLMA004. Both documents are available at www.ti.com.

The exposed thermal pad dimensions for this package are shown in the following illustration.

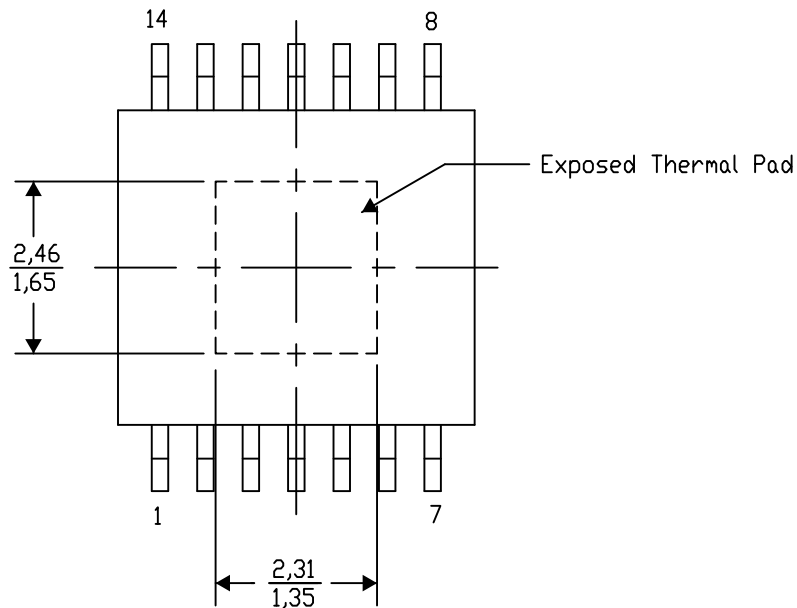

Top View

Exposed Thermal Pad Dimensions

4206332-2/AO 01/16

NOTE: A. All linear dimensions are in millimeters

PowerPAD is a trademark of Texas Instruments

PWP (R-PDSO-G14)

PowerPAD™ PLASTIC SMALL OUTLINE



- NOTES:
- A. All linear dimensions are in millimeters.
 - B. This drawing is subject to change without notice.
 - C. Customers should place a note on the circuit board fabrication drawing not to alter the center solder mask defined pad.
 - D. This package is designed to be soldered to a thermal pad on the board. Refer to Technical Brief, PowerPAD Thermally Enhanced Package, Texas Instruments Literature No. SLMA002, SLMA004, and also the Product Data Sheets for specific thermal information, via requirements, and recommended board layout. These documents are available at www.ti.com <<http://www.ti.com>>. Publication IPC-7351 is recommended for alternate designs.
 - E. Laser cutting apertures with trapezoidal walls and also rounding corners will offer better paste release. Customers should contact their board assembly site for stencil design recommendations. Example stencil design based on a 50% volumetric metal load solder paste. Refer to IPC-7525 for other stencil recommendations.
 - F. Customers should contact their board fabrication site for solder mask tolerances between and around signal pads.

重要声明和免责声明

TI“按原样”提供技术和可靠性数据（包括数据表）、设计资源（包括参考设计）、应用或其他设计建议、网络工具、安全信息和其他资源，不保证没有瑕疵且不做任何明示或暗示的担保，包括但不限于对适销性、某特定用途方面的适用性或不侵犯任何第三方知识产权的暗示担保。

这些资源可供使用 TI 产品进行设计的熟练开发人员使用。您将自行承担以下全部责任：(1) 针对您的应用选择合适的 TI 产品，(2) 设计、验证并测试您的应用，(3) 确保您的应用满足相应标准以及任何其他功能安全、信息安全、监管或其他要求。

这些资源如有变更，恕不另行通知。TI 授权您仅可将这些资源用于研发本资源所述的 TI 产品的应用。严禁对这些资源进行其他复制或展示。您无权使用任何其他 TI 知识产权或任何第三方知识产权。您应全额赔偿因在这些资源的使用中对 TI 及其代表造成的任何索赔、损害、成本、损失和债务，TI 对此概不负责。

TI 提供的产品受 [TI 的销售条款](#) 或 [ti.com](#) 上其他适用条款/TI 产品随附的其他适用条款的约束。TI 提供这些资源并不会扩展或以其他方式更改 TI 针对 TI 产品发布的适用的担保或担保免责声明。

TI 反对并拒绝您可能提出的任何其他或不同的条款。

邮寄地址：Texas Instruments, Post Office Box 655303, Dallas, Texas 75265

Copyright © 2022，德州仪器 (TI) 公司