

抗辐射 V 类，移相谐振控制器

查询样片: [UC1875-SP](#)

特性

- 符合 **QML-V, SMD 5962-94555** 标准
 - 抗辐射: **50kRad (Si)** 总电离辐射剂量 (TID) ⁽¹⁾
 - 零到 **100%** 占空比控制
 - 可编程输出接通延迟
 - 与电压或者电流模式拓扑兼容
 - 在 **1MHz** 开关频率下实际运行
 - **4 个 2A** 推拉输出电路输出
 - **10MHz** 误差放大器
- 欠压闭锁
 - 低启动电流 - **150µA**
 - 在欠压闭锁 (**UVLO**) 期间输出低电平有效
 - 软启动控制
 - 具有全周期重启功能的门锁过流比较器
 - 可调基准
- (1) 抗辐射是基于初始器件限定剂量率 = 10mrad/s 的一个典型值, 并且被施加到 5962-9455502 器件。提供辐射批次验收测试 – 联系工厂了解详细信息。

应用范围

- 电源现场可编程门阵列 (**FPGA**)

说明

UC1875-SP 根据另外一个半桥, 通过一个半桥上的相位移动来控制一个桥电源级, 在高频率下, 为了获得高效性能, 允许持续频率脉宽调制与谐振, 零电压开关相组合。此电路可被配置为在电压或者电源模式下提供控制功能, 此分离的过流关断以实现快速故障保护。

提供一个可编程时间延迟, 在每个输出级接通时插入一个死区时间。此延迟, 为谐振开关动作提供了时间, 并可被每个输出对 (**A-B, C-D**) 单独控制。

借助于工作频率超过 **2MHz** 的振荡器, 实际总开关频率可达到 **1MHz**。

除了标准自由模式, 通过使用时钟同步 (**CLOCLSYNC**) 引脚, 用户可以配置这些器件以接收一个外部时钟同步信号, 或者也可以在最快器件决定的运行频率上锁定最多 **5** 个单位。

保护特性包括一个欠压闭锁, 此特性将所有输出保持在一个低电平有效的状态直到电源达到 **10.75V** 的阈值。为了获得可靠、自举芯片电源, 内置 **1.5** 滞后。还提供过载保护功能, 在故障时, 将会在 **70ns** 内把此输出锁定在关闭 (**OFF**) 状态。此电流故障电路执行满周期重启操作。

额外的特性包括一个带宽超过 **7MHz** 的误差放大器, 一个 **5V** 基准, 提供软启动, 和灵活的斜坡生成和斜率补偿电路。

此器件采用玻璃密封陶瓷双列直插式, 表面贴装, 和陶瓷无引线芯片载体封装, 额定温度范围 **-55°C** 至 **+125°C**。



Please be aware that an important notice concerning availability, standard warranty, and use in critical applications of Texas Instruments semiconductor products and disclaimers thereto appears at the end of this data sheet.

方框图

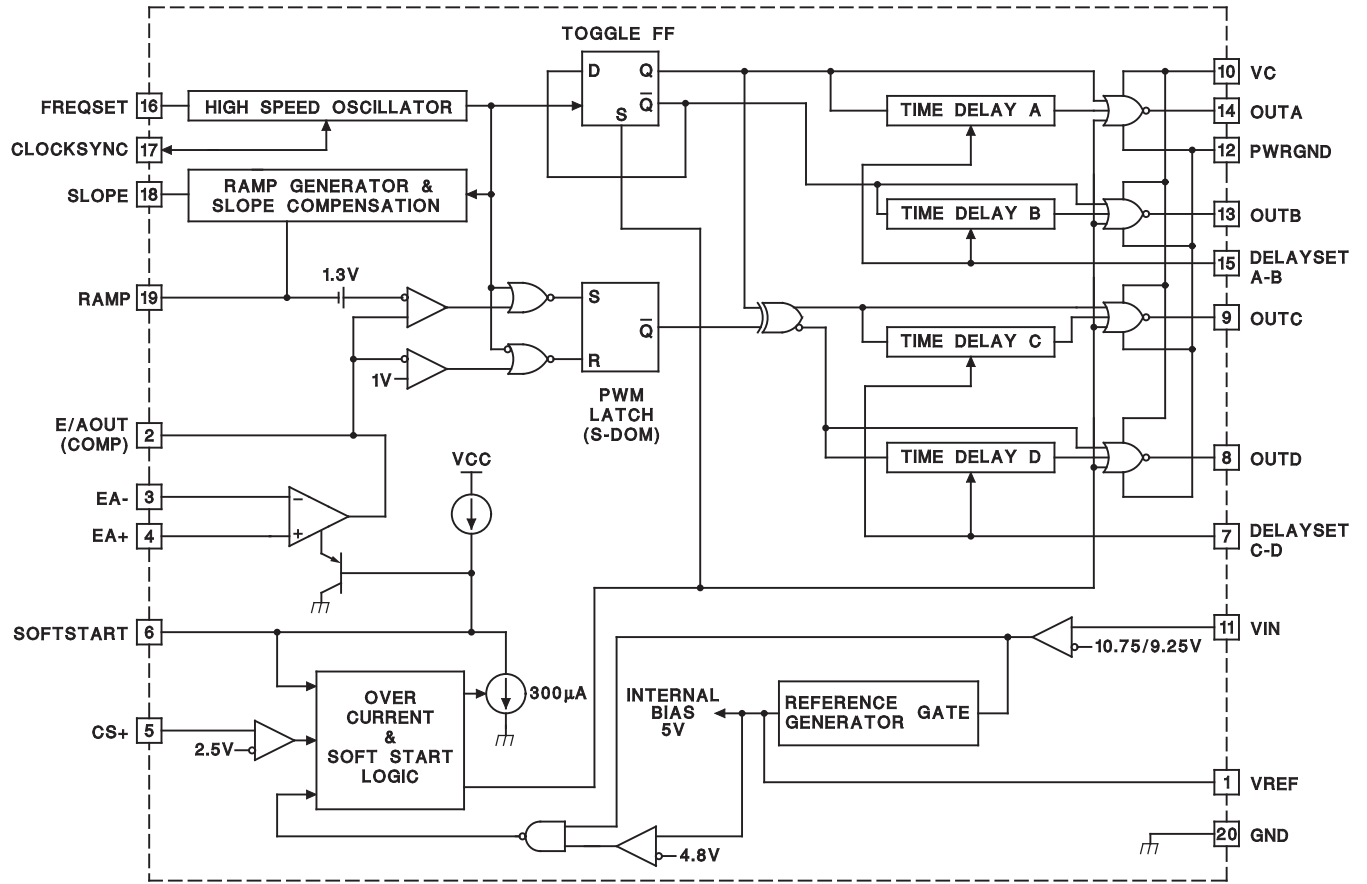



These devices have limited built-in ESD protection. The leads should be shorted together or the device placed in conductive foam during storage or handling to prevent electrostatic damage to the MOS gates.

ORDERING INFORMATION

T _A	PACKAGE	ORDERABLE PART NUMBER	TOP-SIDE MARKING
-55°C to 125°C	CDIP (J)	5962-9455501VRA	5962-9455501VRA
		5962-9455502VRA	5962-9455502VRA
	LCCC (FK)	5962-9455501V3A	5962-9455501V3A
	CFP (W)	5962-9455502VKA	5962-9455502VKA

ABSOLUTE MAXIMUM RATINGS⁽¹⁾

PARAMETER	VALUE		UNIT
	MIN	MAX	
Supply voltage (V _C , V _{IN})		20	V
Output current, source or sink			
DC		0.5	A
Pulse (0.5 μs)		3	A
Analog inputs			
(Pins 1, 2, 3, 4, 5, 6, 7, 15, 16, 17, 18, 19)	-0.3	5.3	V
Storage temperature range	-65	150	°C
Maximum junction temperature, J _{Tmax}		150	
Thermal Resistance T _{JC}			
J package		7	°C/W
W package		5.4	
FK package		5.6	

(1) Pin references are to 20-pin packages. All voltages are with respect to ground. Currents are positive into, negative out of the device terminals.

DEVICE INFORMATION

	UVLO Turn-On	UVLO Turn-Off	Delay Set
UCC1875-SP	10.75V	9.25V	Yes

DIL - 20 Pin
J Package
(TOP VIEW)

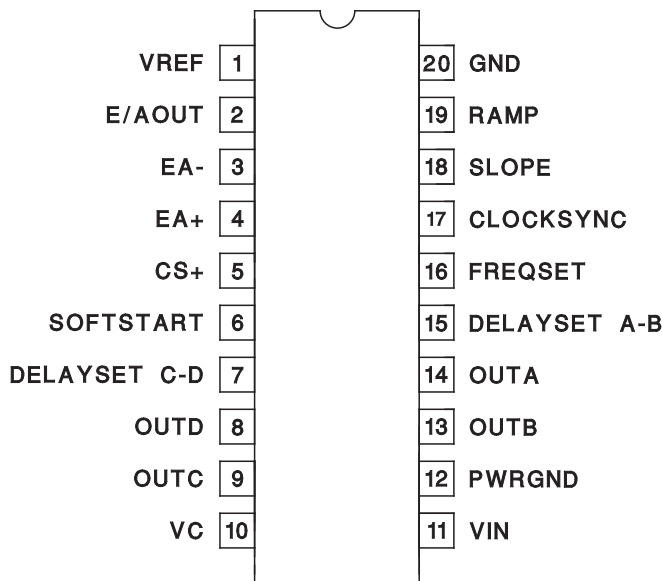

LCCC - 28 Pin
FK Package
(TOP VIEW)

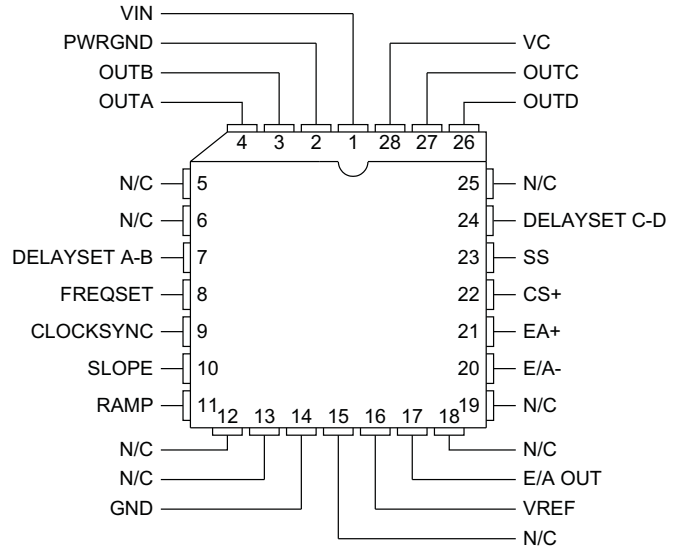

CFP - 24 Pin
W Package
(TOP VIEW)

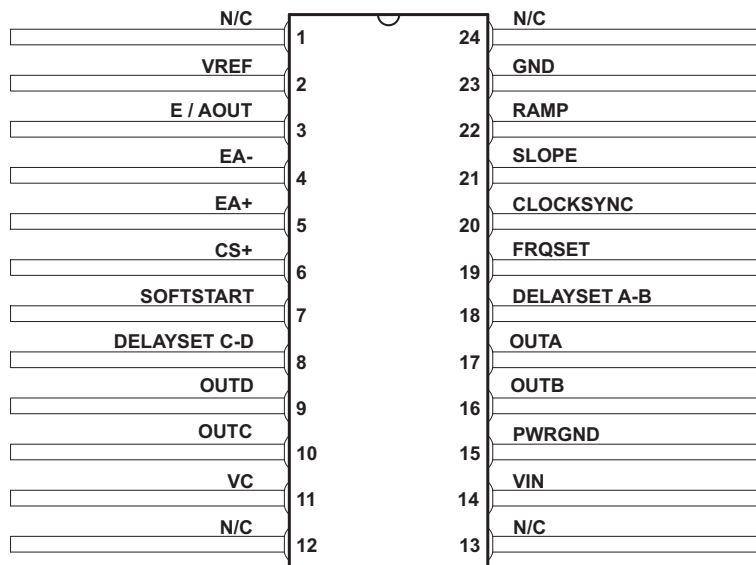

ELECTRICAL CHARACTERISTICS

–55°C < T_A < 125°C. V_C = V_{IN} = 12 V, R_(FREQSET) = 12 kΩ, C_(FREQSET) = 330 pF, R_(SLOPE) = 12 kΩ, C_(RAMP) = 200 pF, C_(DELAYSET A-B) = C_(DELAYSET C-D) = 0.01 μF, I_(DELAYSET A-B) = I_(DELAYSET C-D) = –500 μA, T_A = T_J, unless otherwise stated.

PARAMETER	TEST CONDITIONS	MIN	TYP	MAX	UNIT	
Undervoltage Lockout						
Start threshold			10.75	11.75	V	
UVLO hysteresis		0.5	1.25	2		
Supply Current						
I _{IN} Startup	V _{IN} = 8 V, V _C = 20 V, R _(SLOPE) open, I _(DELAY) = 0		150	600	μA	
I _C Startup	V _{IN} = 8 V, V _C = 20 V, R _(SLOPE) open, I _(DELAY) = 0		10	100		
I _{IN}			30	44	mA	
I _C			15	30		
Voltage Reference						
Output voltage	T _J = 25°C	4.92	5	5.08	V	
Line regulation	11 V < V _{IN} < 20 V		1	10	mV	
Load regulation	I _{VREF} = –10 mA		5	20		
Total variation	Line, Load, Temperature	4.9		5.1	V	
Noise Voltage	10 Hz to 10 kHz		50		μVrms	
Long Term Stability	T _J = 125°C, 1000 hours		2.5		mV	
Short circuit current	V _{REF} = 0 V, T _J = 25°C		60		mA	
Error Amplifier						
Offset voltage			5	15	mV	
Input bias current			0.6	3	μA	
AVOL	1 V < V _(E/AOUT) < 4 V	60	90		dB	
CMMR	1.5 V < V _{CM} < 5.5 V	75	95		dB	
PSRR	11 V < V _{IN} < 20 V	85	100		dB	
Output sink current	V _(E/AOUT) = 1 V	1	2.5		mA	
Output source current	I _(E/AOUT) = 4 V		–1.3	–0.5	mA	
Output voltage high	I _(E/AOUT) = –0.5 mA	4	4.7	5	V	
Output voltage low	I _(E/AOUT) = 1 mA	0	0.5	1	V	
Unity Gain BW	See ⁽¹⁾	01 device	5		MHz	
		02 device	7			
Slew rate	See ⁽¹⁾	6	11		V/μsec	
PWM Comparator						
RAMP offset voltage	T _J = 25°C ⁽²⁾		1.3		V	
Zero phase shift voltage	See ⁽³⁾	0.55	0.9		V	
PWM phase shift ⁽⁴⁾ ⁽⁵⁾	V _(E/AOUT) > (Ramp Peak + Ramp Offset)	01 device	98	99.5	102	%
		02 device	96	100	104	
	V _(E/AOUT) < Zero Phase Shift Voltage	0	0.5	2	%	
Output skew ⁽⁴⁾ ⁽⁵⁾	V _(E/AOUT) > 1 V		5	±20	nsec	
Ramp to output delay ⁽⁶⁾ ⁽¹⁾			65	125		

(1) Not production tested.

(2) Ramp offset voltage has a temperature coefficient of about –4 mV/°C.

(3) The zero phase shift voltage has a temperature coefficient of about –2 mV/°C.

(4) Phase shift percentage (0% = 0, 100% = 180) is defined as $\theta = \frac{200}{T} \phi\%$ where θ is the phase shift, and T are defined in Figure 1. At 0% phase shift, is the output skew.

(5) Not production tested at –55°C.

(6) Ramp delay to output time is defined in Figure 1

ELECTRICAL CHARACTERISTICS (continued)

$-55^{\circ}\text{C} < T_A < 125^{\circ}\text{C}$. $V_C = V_{IN} = 12\text{ V}$, $R_{(\text{FREQSET})} = 12\text{ k}\Omega$, $C_{(\text{FREQSET})} = 330\text{ pF}$, $R_{(\text{SLOPE})} = 12\text{ k}\Omega$, $C_{(\text{RAMP})} = 200\text{ pF}$,
 $C_{(\text{DELAYSET A-B})} = C_{(\text{DELAYSET C-D})} = 0.01\text{ }\mu\text{F}$, $I_{(\text{DELAYSET A-B})} = I_{(\text{DELAYSET C-D})} = -500\text{ }\mu\text{A}$, $T_A = T_J$, unless otherwise stated.

PARAMETER	TEST CONDITIONS	MIN	TYP	MAX	UNIT	
Oscillator						
Initial accuracy	$T_A = 25^{\circ}\text{C}$	01 device	0.85	1	1.15	MHz
		02 device	0.85	1	1.19	
Voltage stability	$11\text{ V} < V_{IN} < 20\text{ V}$		0.2	2	%	
Total variation	Line, Temperature		0.8	1.2	MHz	
Sync pin threshold	$T_J = 25^{\circ}\text{C}$		3.8		V	
Clock out peak	$T_J = 25^{\circ}\text{C}$		4.3			
Clock out low	$T_J = 25^{\circ}\text{C}$		3.3			
Clock out pulse width	$R_{(\text{CLOCKSYN})} = 3.9\text{ k}\Omega$		30	100	nsec	
Maximum frequency ⁽⁷⁾	$R_{(\text{FREQUSET})} = 5\text{ k}\Omega$	2			MHz	
Ramp Generator/Slope Compensation						
Ramp current, minimum	$I_{(\text{SLOPE})} = 10\text{ }\mu\text{A}$, $V_{(\text{FREQSET})} = V_{\text{REF}}$		-11	-14	μA	
Ramp current, maximum	$I_{(\text{SLOPE})} = 1\text{ mA}$, $V_{(\text{FREQSET})} = V_{\text{REF}}$	-0.8	-0.95		mA	
Ramp valley			0		V	
Ramp peak - clamping level	$R_{(\text{FREQSET})} = 100\text{ k}\Omega$	3.8	4.1	5	V	
Current Limit						
Input bias	$V_{\text{CS}+} = 3\text{ V}$		2	5	μA	
Threshold voltage		2.4	2.5	2.6	V	
Delay to output ⁽⁸⁾			85	150	nsec	
Soft Start/Reset Delay						
Charge current	$V_{(\text{SOFTSTART})} = 0.5\text{ V}$	-20	-9	-3	μA	
Discharge current	$V_{(\text{SOFTSTART})} = 1\text{ V}$	120	230			
Restart threshold		4.3	4.7		V	
Discharge level			300		mV	
Output Drivers						
Output low level	$I_{\text{OUT}} = 50\text{ mA}$		0.2	0.4	V	
Output high level	$I_{\text{OUT}} = -50\text{ mA}$		1.5	2.5		
Delay Set						
Delay set voltage	$I_{(\text{DELAY})} = -500\text{ }\mu\text{A}$	2.3	2.4	2.6	V	
Delay time ⁽⁸⁾	$I_{(\text{DELAY})} = -250\text{ }\mu\text{A}$ ⁽⁹⁾	150	250	600	nsec	

(7) Not production tested at -55°C .

(8) Not production tested.

(9) Delay time can be programmed via resistors from the delay set pins to ground. Delay time = $\frac{62.5 \times 10^{-12}}{I_{(\text{DELAY})}}$.

Where $I_{(\text{DELAY})} = \frac{\text{Delay set voltage}}{R_{(\text{DELAY})}}$. The Recommended range for $I_{(\text{DELAY})}$ is $25\text{ }\mu\text{A} \leq I_{(\text{DELAY})} \leq 1\text{ mA}$.

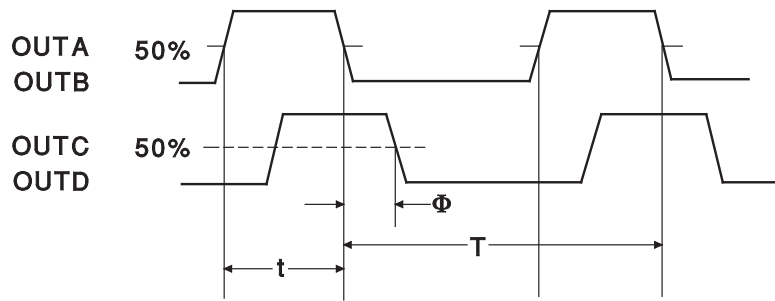

Duty Cycle = t/T , Period = T

$T_{DHL} (A \text{ to } C) = T_{DHL} (B \text{ to } D) = \Phi$

Figure 1. Phase Shift, Output Skew and Delay Time Definitions

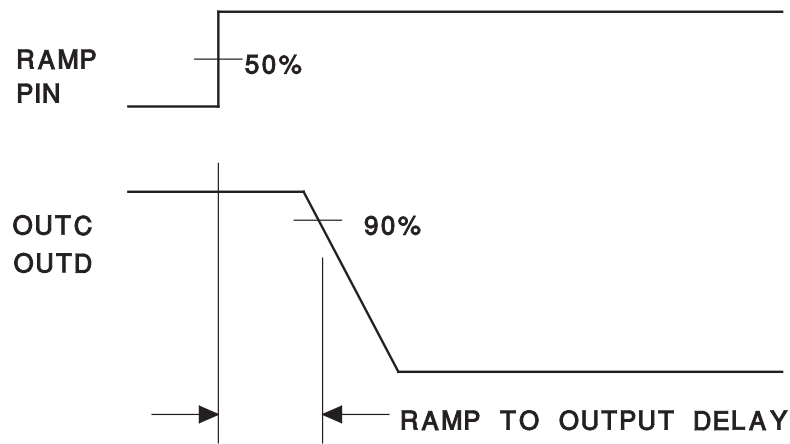

Figure 2. Ramp to Delay Output

PIN DESCRIPTIONS

CLKSYNC (bi-directional clock and synchronization pin): Used as an output, this pin provides a clock signal. As an input, this pin provides a synchronization point. In its simplest usage, multiple devices, each with their own local oscillator frequency, may be connected together by the CLOCKSINC pin and will synchronize on the fastest oscillator. This pin may also be used to synchronize the device to an external clock, provided the external signal is of higher frequency than the local oscillator. A resistor load may be needed on this pin to minimize the clock pulse width.

E/AOUT (Error Amplifier Output): This is the gain stage for overall feedback control. Error amplifier output voltage levels below 1 volt will force 0° phase shift. Since the error amplifier has a relatively low current drive capability, the output may be overridden by driving with a sufficiently low impedance source.

CS+ (Current Sense): The non-inverting input to the current-fault comparator whose reference is set internally to a fixed 2.5 V (separate from VREF). When the voltage at this pin exceeds 2.5 V the current-fault latch is set, the outputs are forced OFF and a SOFT-START cycle is initiated. If a constant voltage above 2.5 V is applied to this pin the outputs are disabled from switching and held in a low state until the CS+ pin is brought below 2.5 V. The outputs may begin switching at 0 degrees phase shift before the SOFTSTART pin begins to rise -- this condition will not prematurely deliver power to the load.

FREQSET (Oscillator Frequency Set pin): A resistor and a capacitor from FREQSET to GND will set the oscillator frequency.

DELSETA-B, DELSETC-D (Output Delay Control): The user programmed current flowing from these pins to GND set the turn-on delay for the corresponding output pair. This delay is introduced between turn-off of one switch and turn-on of another in the same leg of the bridge to provide a dead time in which the resonant switching of the external power switches takes place. Separate delays are provided for the two half-bridges to accommodate differences in the resonant capacitor charging currents.

EA- (Error Amplifier Inverting Input): This is normally connected to the voltage divider resistors which sense the power supply output voltage level.

EA+ (Error Amplifier Non-Inverting Input): This is normally connected to a reference voltage used for comparison with the sensed power supply output voltage level at the EA+ pin.

GND (Signal Ground): All voltages are measured with respect to GND. The timing capacitor, on the FREQSET pin, any bypass capacitor on the VREF pin, bypass capacitors on VIN and the ramp capacitor, on the RAMP pin, should be connected directly to the ground plane near the signal ground pin.

OUTA – OUTD (Outputs A-D): The outputs are 2 A totem-pole drivers optimized for both MOSFET gates and level-shifting transformers. The outputs operate as pairs with a nominal 50% duty-cycle. The A-B pair is intended to drive one half-bridge in the external power stage and is synchronized with the clock waveform. The C-D pair will drive the other half-bridge with switching phase shifted with respect to the A-B outputs.

PWRGND (Power Ground): VC should be bypassed with a ceramic capacitor from the VC pin to the section of the ground plane that is connected to PWRGND. Any required bulk reservoir capacitor should parallel this one. Power ground and signal ground may be joined at a single point to optimize noise rejection and minimize DC drops.

RAMP (Voltage Ramp): This pin is the input to the PWM comparator. Connect a capacitor from here to GND. A voltage ramp is developed at this pin with a slope:

$$\frac{dV}{dT} = \frac{\text{Sense Voltage}}{R_{(\text{SLOPE})} \times C_{(\text{RAMP})}}$$

Current mode control may be achieved with a minimum amount of external circuitry, in which case this pin provides slope compensation.

Because of the 1.3 V offset between the ramp input and the PWM comparator, the error amplifier output voltage can not exceed the effective ramp peak voltage and duty cycle clamping is easily achievable with appropriate values of $R_{(\text{SLOPE})}$ and $C_{(\text{RAMP})}$.

SLOPE (Set Ramp Slope/Slope Compensation): A resistor from this pin to VCC will set the current used to generate the ramp. Connecting this resistor to the DC input line voltage will provide voltage feed-forward.

SOFTSTART:(soft start): SOFTSTART will remain at GND as long as VIN is below the UVLO threshold. SOFTSTART will be pulled up to about 4.8 V by an internal 9 μ A current source when VIN becomes valid (assuming a non-fault condition). In the event of a current-fault (CS+ voltage exceeding 2.5 V), SOFTSTART will be pulled to GND and then ramp to 4.8 V. If a fault occurs during the SOFTSTART cycle, the outputs will be immediately disabled and SOFTSTART must charge fully prior to resetting the fault latch.

For paralleled controllers, the SOFTSTART pins may be paralleled to a single capacitor, but the charge currents will be additive.

VC (Output Switch Supply Voltage): This pin supplies power to the output drivers and their associated bias circuitry. Connect VC to a stable source above 3 V for normal operation, above 12 V for best performance. This supply should be bypassed directly to the PWRGND pin with low ESR, low ESL capacitors

VIN (Primary Chip Supply Voltage): This pin supplies power to the logic and analog circuitry on the integrated circuit that is not directly associated with driving the output stages. Connect VIN to a stable source above 12 V for normal operation. To ensure proper chip functionality, these devices will be inactive until VIN exceeds the upper undervoltage lockout threshold. This pin should be bypassed directly to the GND pin with low ESR, low ESL capacitors.

NOTE

When VIN exceeds the UVLO threshold the supply current (I_{IN}) will jump from about 100 μ A to a current in excess of 20 μ A. If the UC1875-SP is not connected to a well bypassed supply, it may immediately enter UVLO again.

VREF: This pin is an accurate 5 V voltage reference. This output is capable of delivering about 60 mA to peripheral circuitry and is internally short circuit current limited. VREF is disabled while VIN is low enough to force the chip into UVLO. The circuit is also in UVLO until VREF reaches approximately 4.75 V. For best results bypass VREF with a 0.1 μ F, low ESR, low ESL, capacitor to the GND pin.

APPLICATION INFORMATION

Undervoltage Lockout Section

When power is applied to the circuit and V_{IN} is below the upper UVLO threshold, I_{IN} will be below $600\ \mu\text{A}$, the reference generator will be off, the fault latch is reset, the soft-start pin is discharged, and the outputs are actively held low. When V_{IN} exceeds the upper UVLO threshold, the reference generator turns on. All else remains in the shut-down mode until the output of the reference, V_{REF} , exceeds $4.75\ \text{V}$.

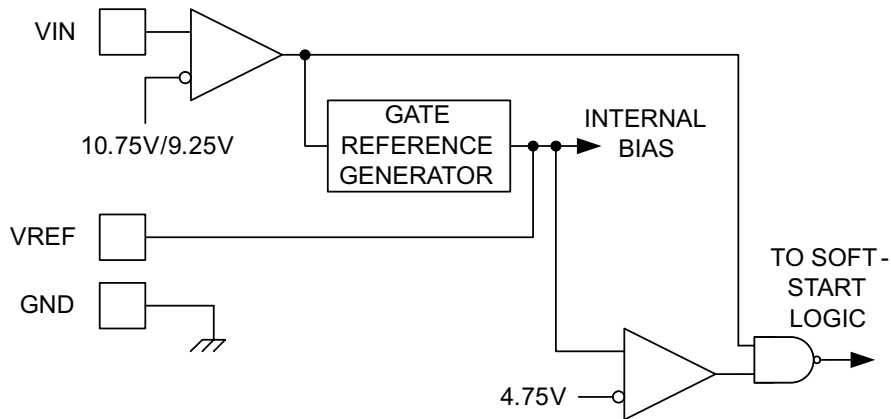

Figure 3. Undervoltage Circuit

The high frequency oscillator may be either free-running or externally synchronized. For free-running operation, the frequency is set via an external resistor and capacitor to ground from the FREQSET pin.

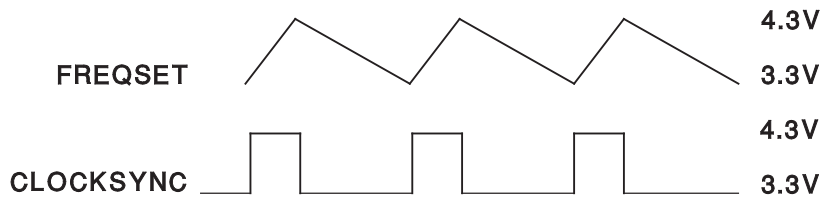
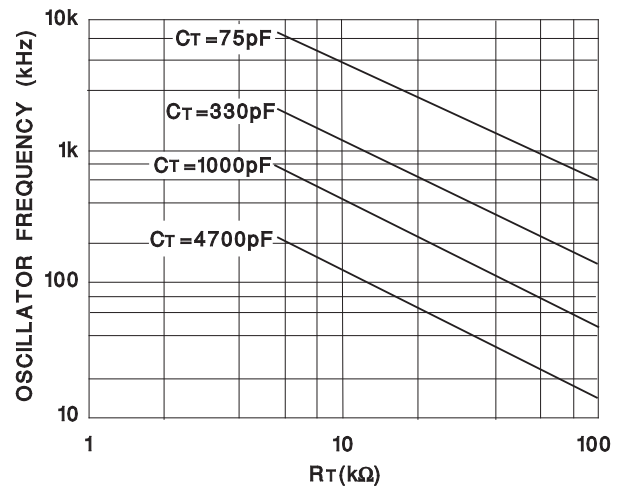
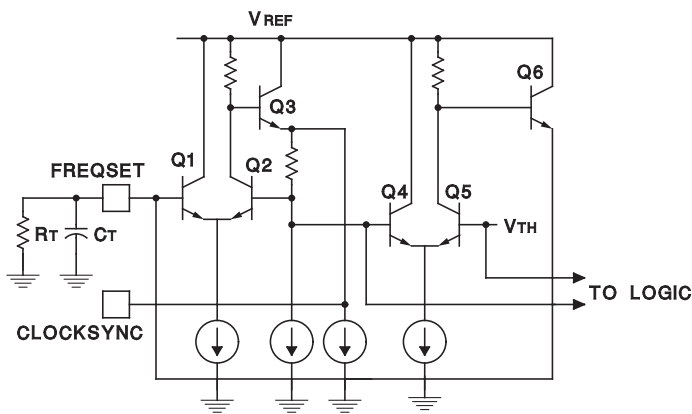

Figure 4. Simplified Oscillator Schematic

Synchronizing The Oscillator

The CLOCKSINC pin of the oscillator may be used to synchronize multiple UC1875-SP device by connecting the CLOCKSINC of each UC1875-SP to the others:

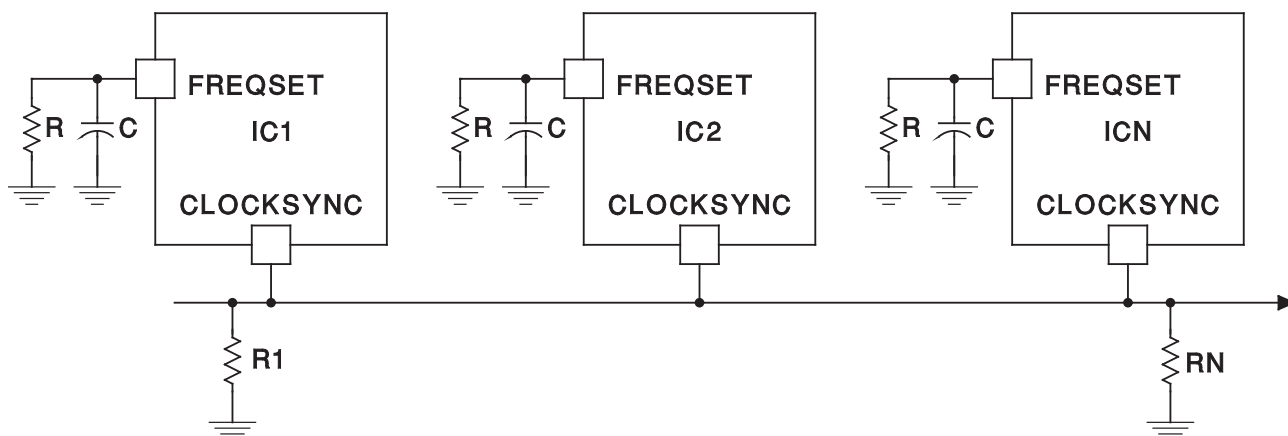

Figure 5.

ALL ICs will sync to the chip with the fastest local oscillator.

R1 and RN may be needed to keep sync pulse narrow due to capacitance on line.

R1 and RN may also be needed to properly terminate $R_{(SYNC)}$ line.

Syncing to External TTL/CMOS

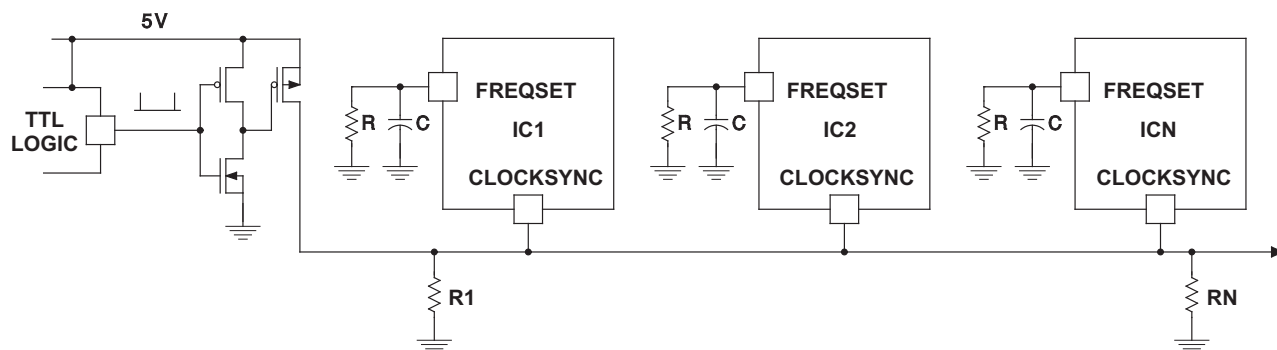

Figure 6.

ICs will sync to the fastest chip or TTL clock if it is higher frequency.

R1 and RN may be needed to keep sync pulse narrow due to capacitance on line.

R1 and RN may also be needed to properly terminate $R_{(SYNC)}$ line.

Although the UC1875-SP has a local oscillator frequency, the device will synchronize to the fastest oscillator driving the CLOCKSINC pin. This arrangement allows the synchronizing connection between ICs to be broken without any local loss of functionality.

Synchronizing the device to an external clock signal may be accomplished with a minimum of external circuitry, as shown in [Figure 6](#).

Capacitive loading on the CLOCKSINC pin will increase the clock pulse width, and may adversely effect system performance. Therefore, a resistor to ground from the CLOCKSINC pin is optional, but may be required to offset capacitive loading on this pin. These resistors are shown in the oscillator schematics as R1, RN.

Delay Blocks and Output Stages

In each of the output stages, transistors Q3 through Q6 form a high-speed totem-pole driver which will source or sink more than one amp peak with a total delay of approximately 30 nanoseconds. To ensure a low output level prior to turn-on, transistors Q7 through Q9 form a self-biased driver to hold Q6 on prior to the supply reaching its turn-on threshold. This circuit is operable when the chip supply is zero. Q6 is also turned on and held low with a signal from the fault logic portion of the chip.

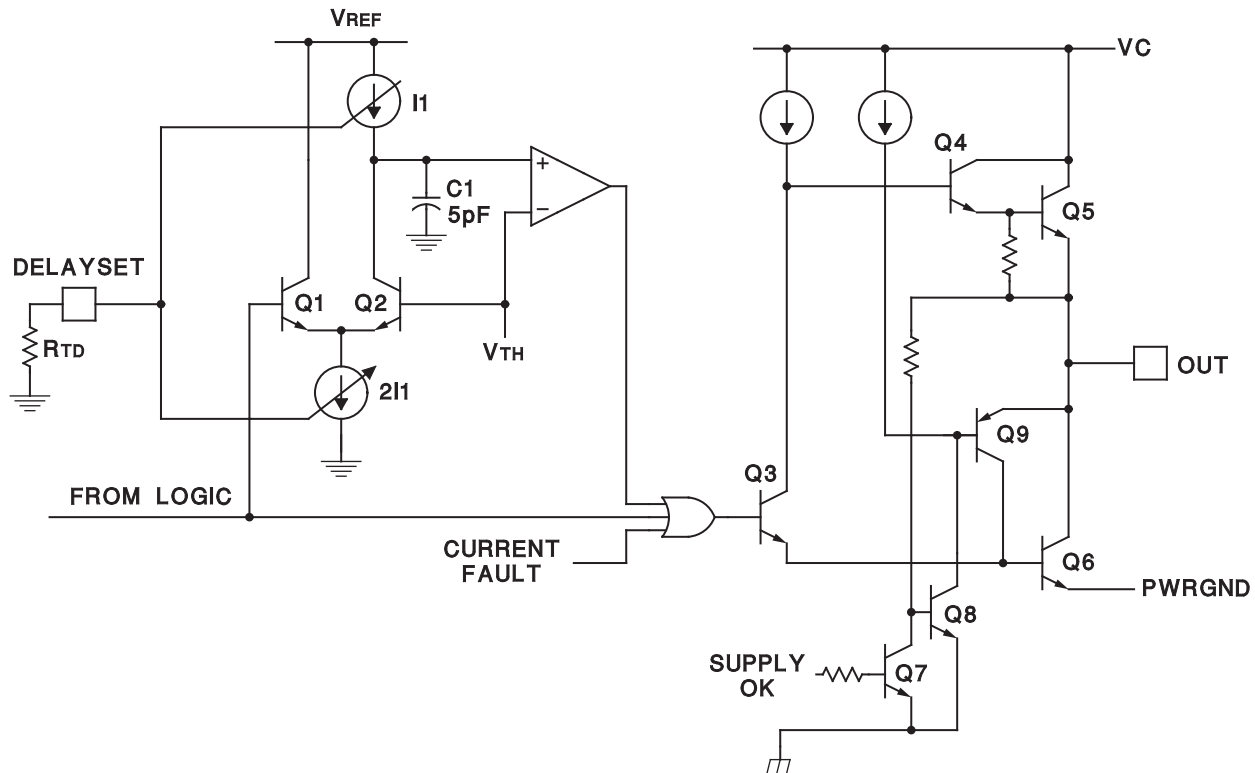

Figure 7.

The delay providing the dead-time is accomplished with C1 which must discharge to V_{TH} before the output can go high. The time is defined by the current sources, I1, which is programmed by an external resistor, R_{TD} . The voltage on the Delay Set pins is internally regulated to 2.5 V and the range of dead time control is from 50 to 200 nanoseconds.

NOTE

There is no way to disable the delay circuitry, and the delay time must be programmed.

Output Switch Orientation

The four outputs of the UC1875-SP interfaces to the full bridge converter switches as shown in [Figure 8](#)

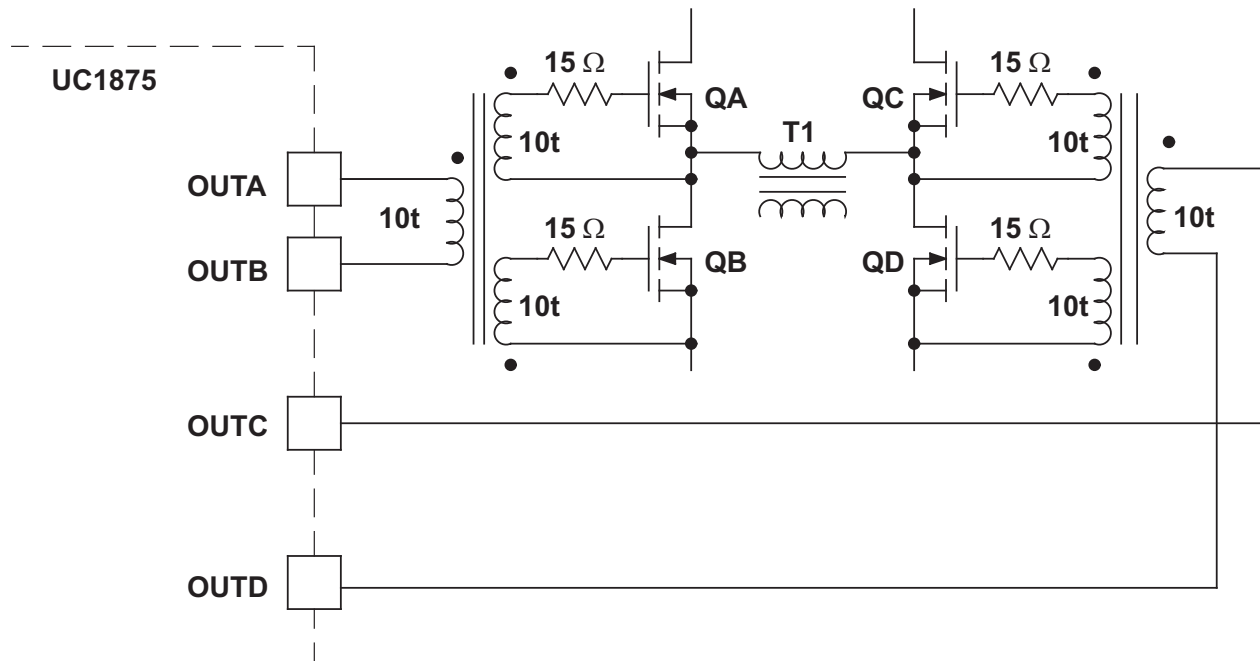

Figure 8. 3 Winding Bifilar, AWG 30 Kynar Insulation

Fault/SoftStart

The fault control circuitry provides two forms of power shutdown:

- Complete turn-off of all four output power stages.
- Clamping the phase shift command to zero.

Complete turn-off is ordered for an over-current fault or a low supply voltage. When the SOFTSTART pin reaches its low threshold, switching is allowed to proceed while the phase-shift is advanced from zero to its nominal value with the time constant of the SOFT-START capacitor.

The fault logic insures that a continuous fault will institute a low frequency “hiccup” retry cycle by forcing the SOFT-START capacitor to charge through its full cycle between each restart attempt.

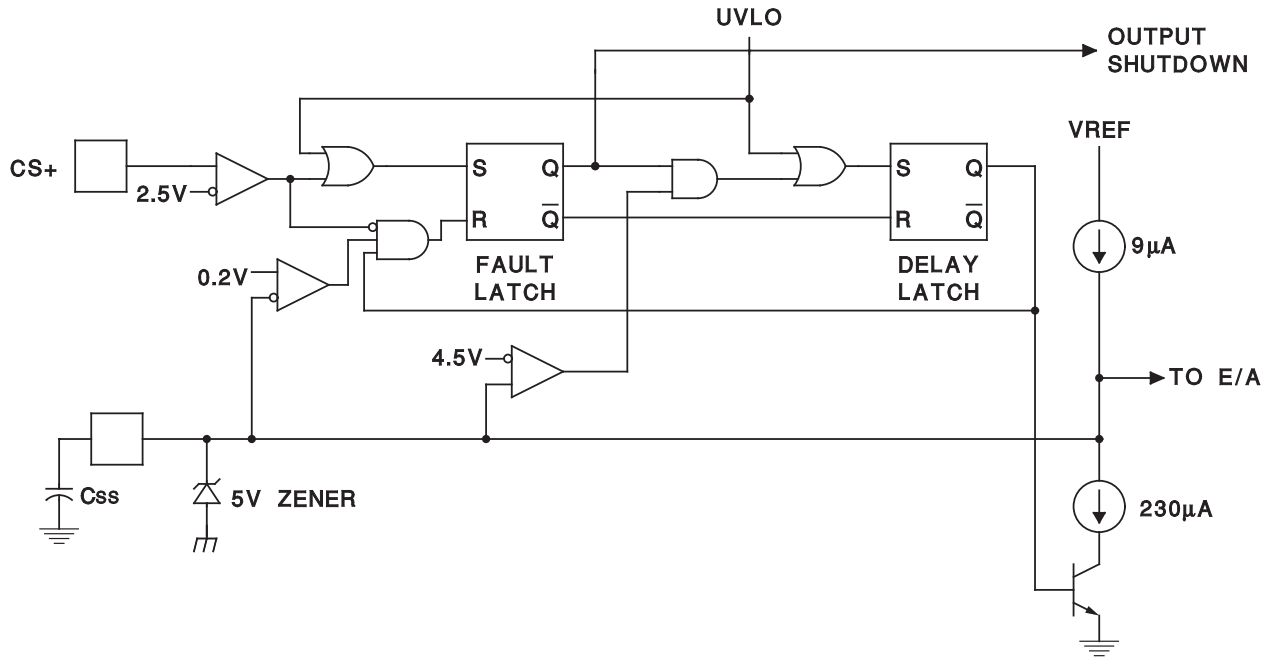

Figure 9.

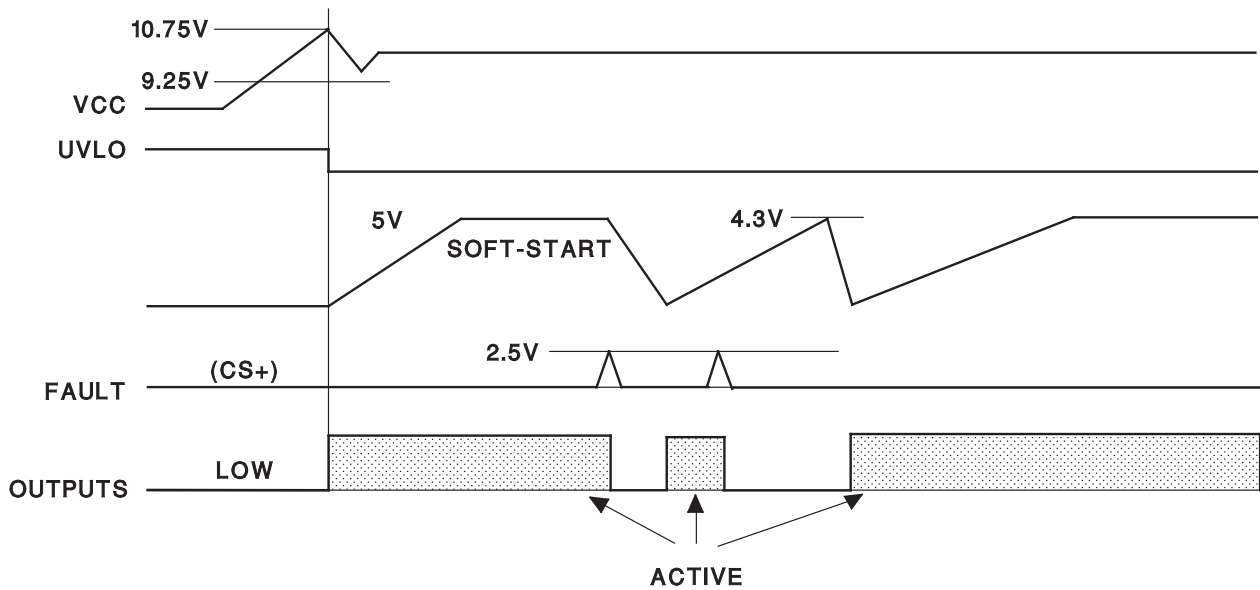

Figure 10.

Slope/Ramp Pins

The ramp generator may be configured for the following control methods:

- Voltage Mode
- Voltage Feedforward
- Current Mode
- Current Mode with Slope Compensation

Figure 11 shows a voltage-mode configuration. With $R_{(SLOPE)}$ tied to a stable voltage source, the waveform on $C_{(RAMP)}$ will be a constant-slope ramp, providing conventional voltage-mode control. If $R_{(SLOPE)}$ is connected to the power supply input voltage, a variable-slope ramp will provide voltage feedforward.

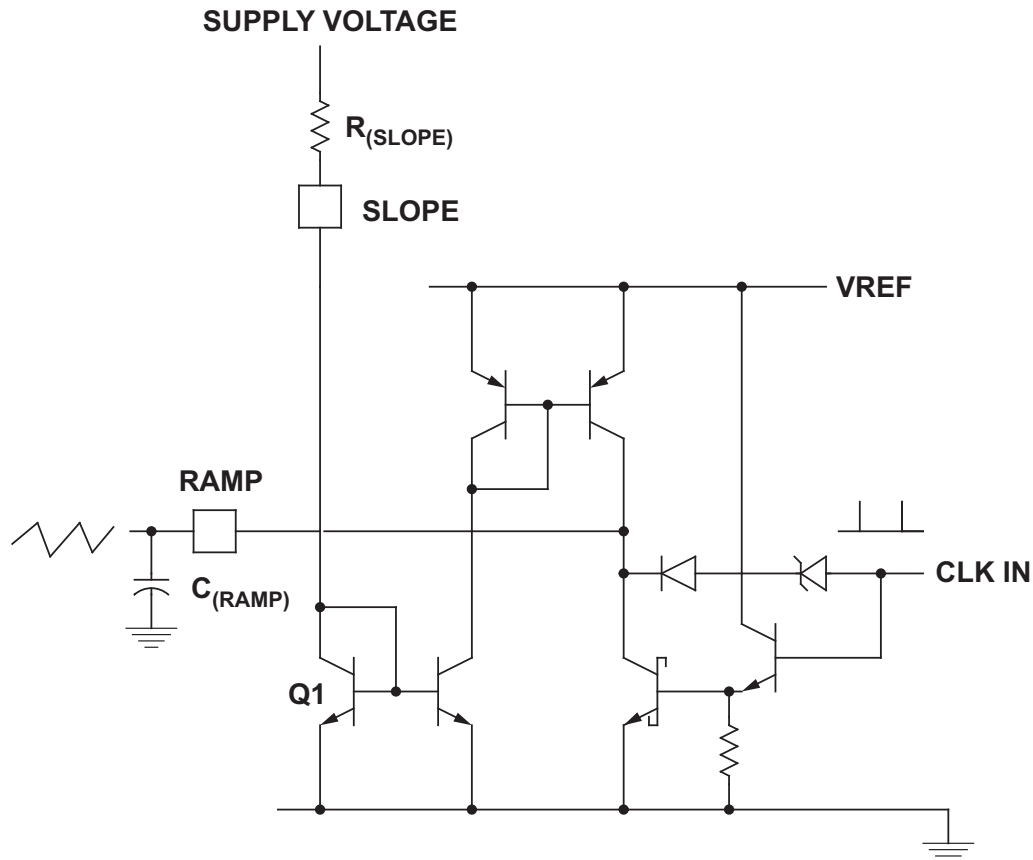

Figure 11. Voltage Mode Operation

1. Simple voltage mode operation achieved by placing $R_{(SLOPE)}$ between V_{IN} and SLOPE
2. Voltage Feedforward achieved by placing $R_{(SLOPE)}$ between supply voltage and SLOPE pin of UC1875-SP.

RAMP:

$$\frac{dV}{dT} = \frac{V_{Rslope}}{R_{SLOPE} \times C_{RAMP}}$$

For current-mode control the ramp generator may be disabled by grounding the slope pin and using the ramp pin as a direct current sense input to the PWM comparator.

PACKAGING INFORMATION

Orderable Device	Status (1)	Package Type	Package Drawing	Pins	Package Qty	Eco Plan (2)	Lead finish/ Ball material (6)	MSL Peak Temp (3)	Op Temp (°C)	Device Marking (4/5)	Samples
5962-9455501VRA	ACTIVE	CDIP	J	20	1	Non-RoHS & Green	SNPB	N / A for Pkg Type	-55 to 125	5962-9455501VRA A UC1875JQMLV	Samples
5962-9455502VKA	ACTIVE	CFP	W	24	1	Non-RoHS & Non-Green	SNPB	N / A for Pkg Type	-55 to 125	5962-9455502VK A UC1875W-SP	Samples
5962-9455502VRA	ACTIVE	CDIP	J	20	1	Non-RoHS & Green	SNPB	N / A for Pkg Type	-55 to 125	5962-9455502VR A UC1875J-SP	Samples

(1) The marketing status values are defined as follows:

ACTIVE: Product device recommended for new designs.

LIFEBUY: TI has announced that the device will be discontinued, and a lifetime-buy period is in effect.

NRND: Not recommended for new designs. Device is in production to support existing customers, but TI does not recommend using this part in a new design.

PREVIEW: Device has been announced but is not in production. Samples may or may not be available.

OBSOLETE: TI has discontinued the production of the device.

(2) **RoHS:** TI defines "RoHS" to mean semiconductor products that are compliant with the current EU RoHS requirements for all 10 RoHS substances, including the requirement that RoHS substance do not exceed 0.1% by weight in homogeneous materials. Where designed to be soldered at high temperatures, "RoHS" products are suitable for use in specified lead-free processes. TI may reference these types of products as "Pb-Free".

RoHS Exempt: TI defines "RoHS Exempt" to mean products that contain lead but are compliant with EU RoHS pursuant to a specific EU RoHS exemption.

Green: TI defines "Green" to mean the content of Chlorine (Cl) and Bromine (Br) based flame retardants meet JS709B low halogen requirements of <=1000ppm threshold. Antimony trioxide based flame retardants must also meet the <=1000ppm threshold requirement.

(3) MSL, Peak Temp. - The Moisture Sensitivity Level rating according to the JEDEC industry standard classifications, and peak solder temperature.

(4) There may be additional marking, which relates to the logo, the lot trace code information, or the environmental category on the device.

(5) Multiple Device Markings will be inside parentheses. Only one Device Marking contained in parentheses and separated by a "~" will appear on a device. If a line is indented then it is a continuation of the previous line and the two combined represent the entire Device Marking for that device.

(6) Lead finish/Ball material - Orderable Devices may have multiple material finish options. Finish options are separated by a vertical ruled line. Lead finish/Ball material values may wrap to two lines if the finish value exceeds the maximum column width.

Important Information and Disclaimer: The information provided on this page represents TI's knowledge and belief as of the date that it is provided. TI bases its knowledge and belief on information provided by third parties, and makes no representation or warranty as to the accuracy of such information. Efforts are underway to better integrate information from third parties. TI has taken and continues to take reasonable steps to provide representative and accurate information but may not have conducted destructive testing or chemical analysis on incoming materials and chemicals. TI and TI suppliers consider certain information to be proprietary, and thus CAS numbers and other limited information may not be available for release.

In no event shall TI's liability arising out of such information exceed the total purchase price of the TI part(s) at issue in this document sold by TI to Customer on an annual basis.

TUBE

*All dimensions are nominal

Device	Package Name	Package Type	Pins	SPQ	L (mm)	W (mm)	T (μm)	B (mm)
5962-9455502VKA	W	CFP	24	1	506.98	26.16	6220	NA
5962-9455502VRA	J	CDIP	20	1	506.98	15.24	13440	NA

W (R-GDFP-F24)

CERAMIC DUAL FLATPACK

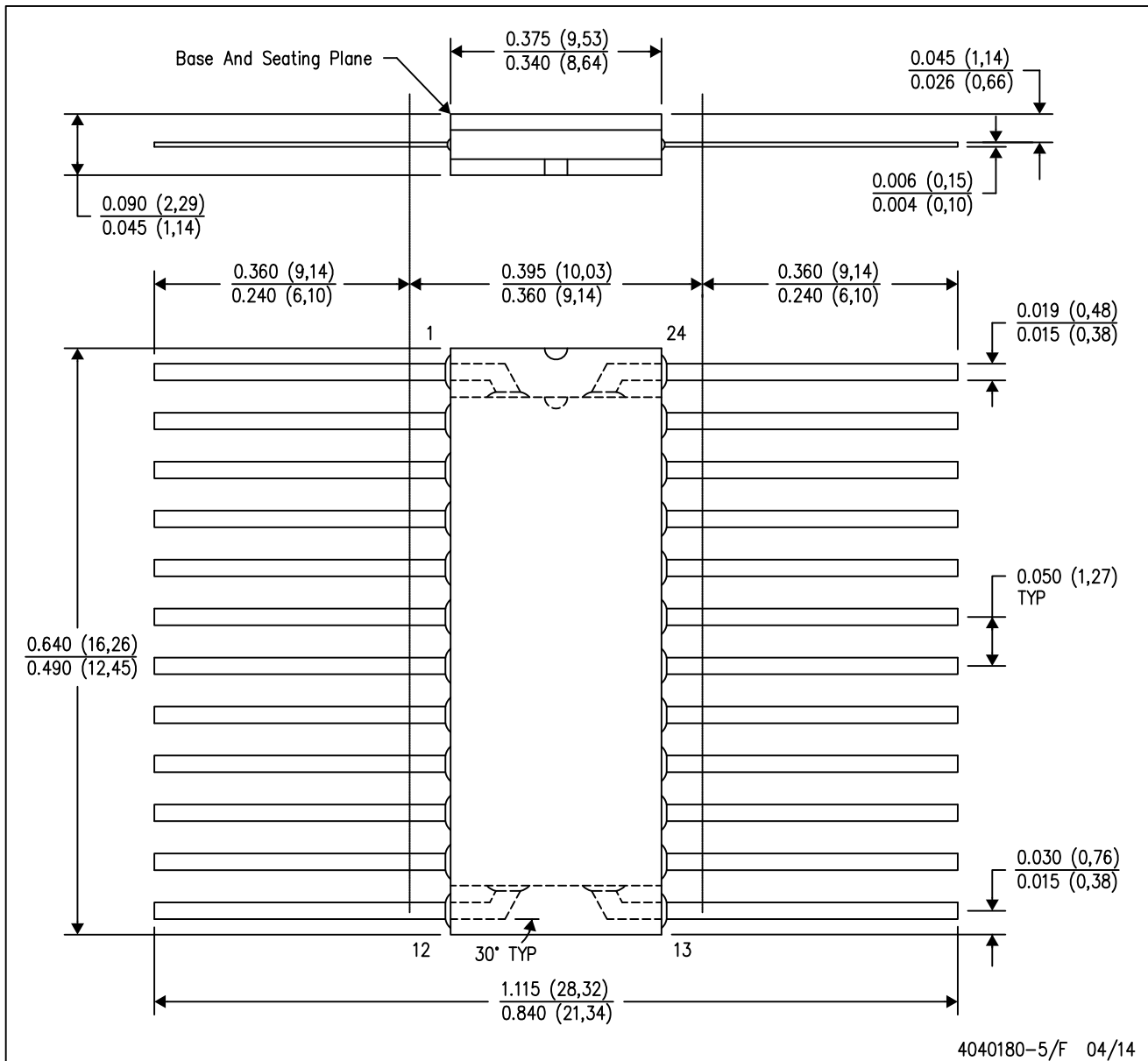

4040180-5/F 04/14

- NOTES:
- A. All linear dimensions are in inches (millimeters).
 - B. This drawing is subject to change without notice.
 - C. This package can be hermetically sealed with a ceramic lid using glass frit.
 - D. Index point is provided on cap for terminal identification only.
 - E. Falls within Mil-Std 1835 GDFP2-F20

J (R-GDIP-T**)

14 LEADS SHOWN

CERAMIC DUAL IN-LINE PACKAGE



DIM \ PINS **	14	16	18	20
A	0.300 (7,62) BSC	0.300 (7,62) BSC	0.300 (7,62) BSC	0.300 (7,62) BSC
B MAX	0.785 (19,94)	.840 (21,34)	0.960 (24,38)	1.060 (26,92)
B MIN	—	—	—	—
C MAX	0.300 (7,62)	0.300 (7,62)	0.310 (7,87)	0.300 (7,62)
C MIN	0.245 (6,22)	0.245 (6,22)	0.220 (5,59)	0.245 (6,22)



4040083/F 03/03

- NOTES:
- All linear dimensions are in inches (millimeters).
 - This drawing is subject to change without notice.
 - This package is hermetically sealed with a ceramic lid using glass frit.
 - Index point is provided on cap for terminal identification only on press ceramic glass frit seal only.
 - Falls within MIL STD 1835 GDIP1-T14, GDIP1-T16, GDIP1-T18 and GDIP1-T20.

重要声明和免责声明

TI“按原样”提供技术和可靠性数据（包括数据表）、设计资源（包括参考设计）、应用或其他设计建议、网络工具、安全信息和其他资源，不保证没有瑕疵且不做任何明示或暗示的担保，包括但不限于对适销性、某特定用途方面的适用性或不侵犯任何第三方知识产权的暗示担保。

这些资源可供使用 TI 产品进行设计的熟练开发人员使用。您将自行承担以下全部责任：(1) 针对您的应用选择合适的 TI 产品，(2) 设计、验证并测试您的应用，(3) 确保您的应用满足相应标准以及任何其他功能安全、信息安全、监管或其他要求。

这些资源如有变更，恕不另行通知。TI 授权您仅可将这些资源用于研发本资源所述的 TI 产品的应用。严禁对这些资源进行其他复制或展示。您无权使用任何其他 TI 知识产权或任何第三方知识产权。您应全额赔偿因在这些资源的使用中对 TI 及其代表造成的任何索赔、损害、成本、损失和债务，TI 对此概不负责。

TI 提供的产品受 [TI 的销售条款](#) 或 [ti.com](#) 上其他适用条款/TI 产品随附的其他适用条款的约束。TI 提供这些资源并不会扩展或以其他方式更改 TI 针对 TI 产品发布的适用的担保或担保免责声明。

TI 反对并拒绝您可能提出的任何其他或不同的条款。

邮寄地址：Texas Instruments, Post Office Box 655303, Dallas, Texas 75265

Copyright © 2022，德州仪器 (TI) 公司